



SIM65M Series Hardware Design

GNSS Module

SIMCom Wireless Solutions Limited

SIMCom Headquarters Building, Building 3, No. 289 Linhong
Road, Changning District, Shanghai P.R. China

Tel: 86-21-31575100

support@simcom.com

www.simcom.com

Document Title:	SIM65M Series Hardware Design
Version:	1.05
Data	2023-09-15
Status:	Released

GENERAL NOTES

SIMCOM OFFERS THIS INFORMATION AS A SERVICE TO ITS CUSTOMERS TO SUPPORT THE APPLICATION AND ENGINEERING EFFORTS THAT USE THE PRODUCTS DESIGNED BY SIMCOM. THE INFORMATION PROVIDED IS BASED ON THE REQUIREMENTS SPECIFICALLY FROM THE CUSTOMERS. SIMCOM HAS NOT UNDERTAKEN ANY INDEPENDENT SEARCH FOR ADDITIONAL RELEVANT INFORMATION, INCLUDING ANY INFORMATION THAT MAY BE IN THE CUSTOMER'S POSSESSION. FURTHERMORE, THE SYSTEM VALIDATION OF THE PRODUCT DESIGNED BY SIMCOM WITHIN A LARGER ELECTRONIC SYSTEM REMAINS THE RESPONSIBILITY OF THE CUSTOMER OR THE CUSTOMER'S SYSTEM INTEGRATOR. ALL SPECIFICATIONS SUPPLIED HEREIN ARE SUBJECT TO CHANGE WITHOUT NOTICE.

COPYRIGHT

THIS DOCUMENT CONTAINS THE PROPRIETARY TECHNICAL INFORMATION WHICH IS THE PROPERTY OF SIMCOM LIMITED, COPYING OF THIS DOCUMENT, GIVING IT TO OTHERS, THE USING OR COMMUNICATION OF THE CONTENTS THEREOF ARE FORBIDDEN WITHOUT THE OFFICIAL AUTHORITY BY SIMCOM. OFFENDERS ARE LIABLE TO THE PAYMENT OF THE DAMAGES. ALL RIGHTS ARE RESERVED IN THE EVENT OF GRANT OF A PATENT OR THE REGISTRATION OF A UTILITY MODEL OR DESIGN. ALL SPECIFICATIONS SUPPLIED HEREIN ARE SUBJECT TO CHANGE WITHOUT NOTICE.

SIMCom Wireless Solutions

SIMCom Headquarters Building, Building 3, No. 289 Linhong Road, Changning District, Shanghai P.R.China

Tel: +86 21 31575100

Email: simcom@simcom.com

For more information, please visit:

<https://www.simcom.com/download/list-863-en.html>

For technical support, or to report documentation errors, please visit:

<https://www.simcom.com/ask/> Or email to: support@simcom.com

Copyright © 2023 SIMCom Wireless Solutions Limited All Rights Reserved.

Version History

Date	Version	Description of change	Author
2022-06-08	V1.01	Origin	Qiu Lei Wentao Tan
2022-10-10	V1.02	Changed the functional framework diagram, as well as part of the module timing diagram Update EINT_IN description. The B1C frequency was increased	Xinao Liu Wentao Tan
2023-04-23	V1.03	<ol style="list-style-type: none"> 1. Revised the active antenna reference design and added the recommended material list for antenna TVS 2. Revised the description of sleep mode and RTC mode 4. Update the module process description 5. Increase the maximum absolute rating of IO pin voltage and other level maximum parameters 6. Modify the function description of the RESET pin 7. Change the GNSS operating frequency 8. Add 3.3V IO level SIM65M-U module 9. Update the current consumption data and add the current consumption data under different satellites 10. Increase REACH certification 	Qiu Lei Wentao Tan
2023-06-06	V1.04	<ol style="list-style-type: none"> 1. Added Packaging Instructions Chapter, Chapter 8 2. Added documentation overview section 1.1 	Qiu Lei
2023-09-15	V1.05	<ol style="list-style-type: none"> 1. Added sub-model SIM65M-W related description Includes chapters 1.1, 1.2, 1.3, 1.5, 1.6, 1.7, 2.1, 2.2, 3.1, 3.3, 3.6, 4.4, 6.1, 6.2 2. Update the description of the production process(Chapter VII in its entirety) 3. Update the supply range value of the SIM65M-U 	Qiu Lei

Contents

1	Introduction	7
1.1	Documentation Overview	8
1.2	Overview	9
1.3	Key Features	9
1.4	SIM65M Series Functional Diagram	10
1.5	GNSS Performance	11
1.6	General features	12
1.7	Power consumption	15
1.8	GNSS operating frequency	15
1.9	A-GPS	17
1.9.1	EPO™	17
1.9.2	EASY™ Mode	17
1.9.3	SBAS and RTCM	18
1.10	LOCUS	18
1.11	AIC	19
1.12	Firmware update	19
2	Package Information	20
2.1	Pin out Diagram	20
2.2	Pin Description	20
2.3	Machine Dimensions	23
3	Application Interface	25
3.1	Power Management	25
3.1.1	Power Input	25
3.1.2	Power on	26
3.1.3	Power off	27
3.1.4	Verification of SIM65M Series Start	27
3.1.5	Power Saving Modes	27
3.2	Operating Mode	28
3.2.1	Full on Mode	28
3.2.2	Sleep Mode	28
3.2.3	RTC mode	29
3.3	VDD_ANT	30
3.4	WAKEUP_OUT Signal	31
3.5	EINT_IN Signal	31
3.6	UART Interface	32
3.7	I2C Interface*	33
3.8	Timemark Output	34
3.9	RESET_N	34
4	Antenna	36
4.1	Antenna Interface	36
4.2	Antenna Choice Consideration	36

4.2.1	Passive Antenna.....	37
4.2.2	Active Antenna	39
5	Anti-Jamming applications	40
5.1	In-band jamming	40
5.2	Out-of-band jamming	41
5.3	Anti-Jamming design.....	41
6	Electrical Characteristics	42
6.1	Absolute Maximum Ratings	42
6.2	Recommended Operating Conditions.....	42
6.3	Electro-Static Discharge	43
7	Manufacturing	44
7.1	Top and bottom View of SIM65M Series	44
7.2	Label Description Information	45
7.3	Recommended PCB Footprint.....	46
7.4	Recommended SMT Stencil	46
7.5	Recommended reflow furnace temperature curve	47
7.6	Moisture Sensitivity Level and Storage conditions	48
7.7	Baking Requirements.....	50
8	Packaging.....	51
8.1	Tray packaging.....	51
8.2	Reel packaging	53
9	Reference Design.....	56
10	Appendix	57
10.1	Related Documents.....	57
10.2	Terms and Abbreviations	57
10.3	Safety Caution.....	58

Table Index

TABLE 1: DOCUMENTATION OVERVIEW.....	8
TABLE 2: GNSS PERFORMANCE	11
TABLE 3: GENERAL FEATURES.....	12
TABLE 4: GENERAL FEATURES.....	12
TABLE 5: GENERAL FEATURES.....	14
TABLE 6: CONSUMPTION DATA (TYPICAL VALUE)	15
TABLE 7: GNSS OPERATING FREQUENCIES.....	16
TABLE 8: I/O PARAMETER DEFINITION	20
TABLE 9: DESCRIPTION OF MODULE DIFFERENCES	21
TABLE 10: PIN DESCRIPTION.....	21
TABLE 11: RECOMMENDED D1 AND D2 LIST.....	26
TABLE 12: POWER SUPPLY AND CLOCK STATE ACCORDING TO OPERATION MODE.....	28
TABLE 13: HOST PORT MULTIPLEXED FUNCTION PINS.....	32
TABLE 14: ANTENNA SPECIFICATIONS.....	37
TABLE 15: TVS RECOMMENDED LIST	38
TABLE 16: ABSOLUTE MAXIMUM RATINGS	41
TABLE 17: ABSOLUTE MAXIMUM RATINGS	42
TABLE 18: SIM65M SERIES OPERATING CONDITIONS	42
TABLE 19: THE ESD CHARACTERISTICS (TEMPERATURE: 25°C, HUMIDITY: 45 %)... ..	43
TABLE 20: LABEL DESCRIPTION OF MODULE INFORMATION	45
TABLE 21: THE MAIN BOARD REFLUX TEMPERATURE CURVE REQUIREMENTS (LEAD-FREE)	47
TABLE 22: MSL LEVELS	49
TABLE 23: BAKING REQUIREMENTS.....	50
TABLE 24: TRAY SIZE.....	52
TABLE 25: SMALL CARTON SIZE	52
TABLE 26: BIG CARTON SIZE	53
TABLE 27: REEL SIZE	54
TABLE 28: PACKING BOX SIZE	55
TABLE 29: BIG CARTON SIZE	55
TABLE 30: RELATED DOCUMENTS	57
TABLE 31: TERMS AND ABBREVIATIONS.....	57
TABLE 32: SAFETY CAUTION	58

Figure Index

FIGURE 1: SIM65M SERIES FUNCTIONAL DIAGRAM	11
FIGURE 2: SIM65M SERIES PIN DIAGRAM (TOP VIEW)	20
FIGURE 3: SIM65M SERIES MECHANICAL DIMENSIONS (UNIT: MM)	23
FIGURE 4: POWER SUPPLY REFERENCE CIRCUIT	25
FIGURE 5: V_BACKUP INPUT REFERENCE CIRCUIT	26
FIGURE 6: TIMING SEQUENCE OF MODULE POWER-ON AND POWER-OFF	27
FIGURE 7: ENTER AND EXIT SOFTWARE RTC MODE	30
FIGURE 8: WAKEUP HOST.....	31
FIGURE 9: CONNECTION OF THE SERIAL INTERFACES	33
FIGURE 10: CONNECTION OF THE I2C INTERFACES.....	33
FIGURE 11: TIMEMARK APPLICATION CIRCUIT	34
FIGURE 12: RESET RECOMMENDED CIRCUIT	35
FIGURE 13: SIM65M SERIES PASSIVE ANTENNA DESIGN	37
FIGURE 14: SIM65M SERIES PASSIVE ANTENNA DESIGN (WITH EXTERNAL LNA AND SAW)	38
FIGURE 15: SIM65M SERIES PASSIVE ANTENNA DESIGN	39
FIGURE 16: SIM65M SERIES ACTIVE ANTENNA DESIGN.....	39
FIGURE 17: TOP AND BOTTOM VIEW OF SIM65M.....	44
FIGURE 18: TOP AND BOTTOM VIEW OF SIM65M-U	44
FIGURE 19: TOP AND BOTTOM VIEW OF SIM65M-W	45
FIGURE 20: LABEL DESCRIPTION OF MODULE INFORMATION	45
FIGURE 21: RECOMMENDED PCB FOOTPRINT (TOP VIEW) (UNIT: MM)	46
FIGURE 22: RECOMMENDED SMT STENCIL(TOP VIEW).....	47
FIGURE 23: RECOMMENDED REFLOW FURNACE TEMPERATURE CURVE (LEAD-FREE).....	47
FIGURE 24: HUMIDITY CARD	49
FIGURE 25: PACKAGING DIAGRAM.....	51
FIGURE 26: TRAY DRAWING	51
FIGURE 27: SMALL CARTON DRAWING	52
FIGURE 28: BIG CARTON DRAWING	52
FIGURE 29: PACKAGING INTRODUCE	53
FIGURE 30: CARRIER TAPE DRAWING INTRODUCE.....	54
FIGURE 31: PACKING BOX DRAWING INTRODUCE	55
FIGURE 32: BIG CARTON DRAWING INTRODUCE	55
FIGURE 33: REFER SCHEMATIC.....	56

1 Introduction

This document describes the hardware interface of the SIMCom module SIM65M Series, SIM65M Series is a high performance and reliable GNSS module. It is a GNSS module integrated with GPS &GLONASS &BEIDOU & Galileo & QZSS system in a LCC type with AIROHA's high sensitivity navigation engine, which allows customer to achieve industry's high level sensitivity, accuracy, and Time-to-First-Fix (TTFF) with lower power consumption.

1.1 Documentation Overview

Technical information for the module is primarily covered by the documents listed in Table 1. All documents must be studied for a thorough understanding of the device and its applications.

Table 1: Documentation Overview

SN	Document Name	Remark
[1]	SIM65M Series_Hardware_Design_V1.05(this document)	It mainly introduces hardware components such as interface functions, recommended circuits, PCB layout guides, packaging, and software instructions
[2]	SIM65M_Low_Power_Application Documentati on _V1.01	It mainly introduces the low-power application method and current consumption data of the module
[3]	SIM65M Series_Power Saving_Application Note	It mainly introduces the considerations for low-power application of modules
[4]	SIM65M and SIM68M-Compatible_Design_V1.00	SIM65M vs. SIM68M comparison document
[5]	SIM65M Series_V1.03_REFDL	SIM65M Series reference design
[6]	SIM65M-EVB_User_Guide_V1.00	Introduction to how to use the SIM65M with EVB
[7]	SIM65M_EVB SCH&PCB	SIM65M-EVB schematic and PCB PDF document
[8]	MOD_SIM65M_18 SCH&PCB	SIM65M module reference package
[9]	SIM65M Series_NMEA Message_User Guide_V1.00	The SIM65M series software instruction pole usage method is introduced in detail
[10]	Module Secondary SMT Process User	This paper mainly introduces the SMT p

Guide_V1.01

rocess of module production, the requirements of steel mesh production, reflow welding, welding and repair

NOTE

This current revision is an early release to support initial product developers. The content is subject to change without advance notice.

1.2 Overview

SIM65M Series provides simultaneous GPS, BEIDOU, GLONASS, Galileo and QZSS open service L1 reception capability. With 33 tracking channels and 99 acquisition channels, SIM65M Series can acquire and track any mix of multiple satellite signals. Combining advanced AGPS called EASY™ (Embedded Assist System) with proven AlwaysLocate™ technology, SIM65M Series achieves the highest performance and fully meets the industrial standard.

1.3 Key Features

The module provides complete signal processing from antenna input to host port in NMEA messages. The SIM65M-W module require 1.75V to 1.95V power supply, SIM65M module requires 2.8V to 4.3V power supply, and SIM65M-U module require 3.0V to 4.3V power supply, which gives customers plenty of choices for the application circuit. The module communicates with the HOST through the UART interface. The SIM65M-W I/O interface level is 1.8V, SIM65M I/O interface level is 2.8V and the SIM65M-U I/O interface level is 3.3V.

SIM65M Series supports the following L1 GNSS band signals:

- GPS, BEIDOU, GLONASS, Galileo also supports QZSS , SBAS.

Besides, module provides the following services:

- Support WAAS/EGNOS/MSAS/GAGAN
- 12 multi-tone AIC in L1 band for removing unwanted signals
- RTCM ready
- Small footprint: 10.1x 9.7 x 2.5mm, 18-pin LCC package
- Support Jamming Removing (AIC)
- Low-noise amplifier has been integrated (LNA)
- Max fixed update rate up to 10 HZ¹
- Advanced software features
 1. Periodic mode/GLP mode for lower power consumption
 2. EPO™ orbit prediction

- 3. EASY™ self-generated orbit prediction
- 4. LOCUS™ logger function
- Pulse-per-second (PPS) GPS time reference
 - 1. Adjustable duty cycle
 - 2. Typical accuracy: +/- 10ns
- Interface²
 - 1. UART * 2 (SIM65M-U supports a serial port)
 - 2. I2C * 1 (Only SIM65M-U is supported)
- Operating temperature: -40 ~ +85°C
- RoHS\REACH compliant

NOTE

- 1. Default is 1 HZ;
- 2. Different module interface configurations are different, please refer to the pin description for details

1.4 SIM65M Series Functional Diagram

The following figure shows a functional diagram of the SIM65M Series and illustrates the mainly functional parts:

- The main chip
- SAW filter
- Integrated LNA
- The antenna interface
- The communication interface
- The control signals

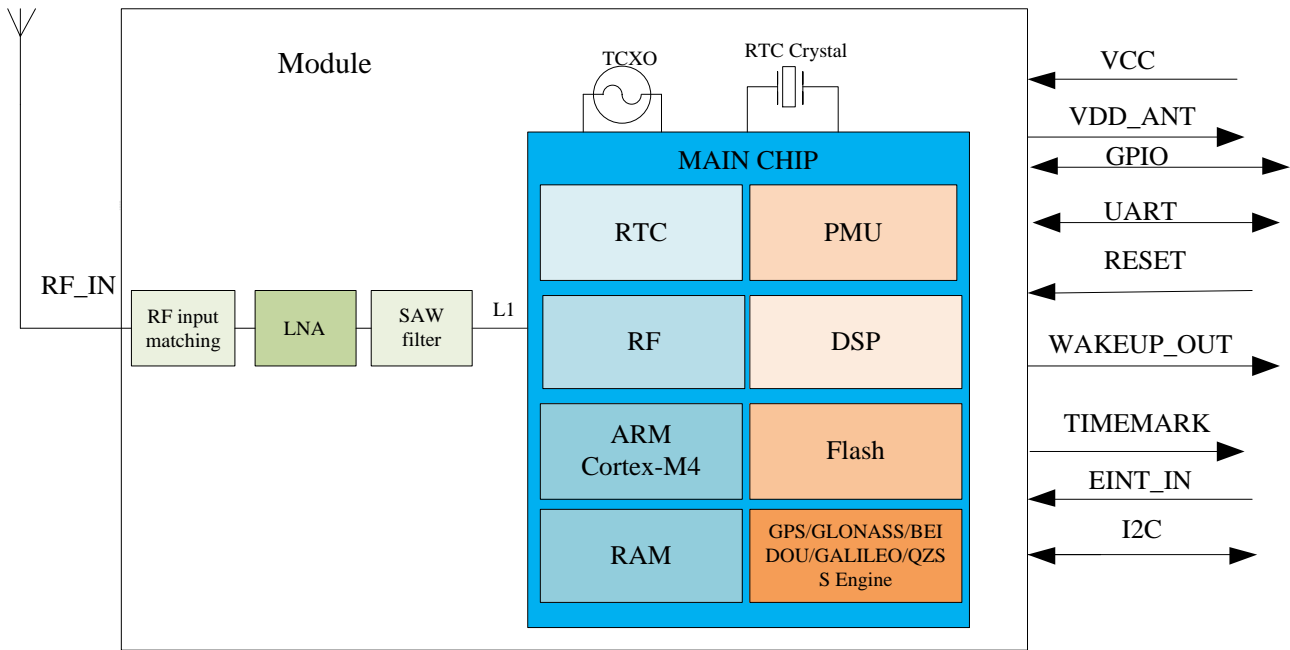

Figure 1: SIM65M Series functional diagram

1.5 GNSS Performance

Table 2: GNSS Performance

Parameter	Description	Performance			
		Min	Type	Max	Unit
Horizontal Position Accuracy ¹	Automatic position		1		m
Velocity Accuracy ²	Without Aid		0.1		m/s
	DGPS		0.05		m/s
Timing Accuracy			10		nS
Dynamic Performance	Maximum Altitude			18000	m
	Maximum Velocity			500	m/s
	Maximum Acceleration			4	G
TTFF with GPS (L1) and GLONASS and BEIDOU mode	Hot start		1.1		S
	Warm start		21.5		S
	Cold start		25.3		S
A-GPS TTFF(EPO in flash mode)	Cold start		3.5		S
Sensitivity with GPS (L1) and GLONASS and BEIDOU mode	Autonomous acquisition(cold start)		-147		dBm
	Re-acquisition		-157.5		dBm
	Tracking		-167		dBm
Receiver	Channels		L1:47		

	Update rate	1	10	Hz
	Tracking L1, CA Code			
	Protocol support NMEA,PAIR			

NOTE

1. 50% 24hr static, -130dBm;
2. 50% at 30m/s;
3. GPS signal level: -130dBm; GLONASS signal level: -130dBm; GALILEO signal level: -130dBm; BEIDOU signal level: -130dBm.

1.6 General features

Table 3: General features

Parameters	Value
Supply voltage VCC	+1.75V~+1.95V typical:1.8V @SIM65M-W +2.8V~4.3V typical:3.3V @ SIM65M +3.0V~4.3V typical:3.3V @ SIM65M-U
Supply voltage ripple VCC	54 mV(RMS) max @ f = 0~3MHz 15 mV(RMS) max @ f > 3 MHz
Storage temperature	-45°C~+95°C
Operating temperature	-40°C~+85°C ¹
Host port	UART0
Other port	I2C, UART2
Serial port protocol (UART)	NMEA; 8 bits, no parity, 1 stop bit; 115200 baud (configurable)
TM output (1PPS)	3D-FIXED 1 pulse per second, synchronized at rising edge, The rising edge of the pulse is aligned with UTC seconds, with an accuracy of about 10nS pulse length 100ms

Table 4: General features

Pin voltage domain	Parameter	Description	Min	Typ	Max
DVDIO=1.8V I/O (V)	V _{IL}	Active low-level input	-0.3 V	-	0.45 V
	V _{IH}	Active high-level input	1.35 V	-	2.1 V

	V_{OL}	Low-level output range	-	-	0.27 V
	V_{OH}	High-level output range	1.53 V	-	-
	R_{PU}	Internal pull-up resistor	70 k Ω	150 k Ω	380 k Ω
	R_{PD}	Internal pull-down resistor	70 k Ω	150 k Ω	380 k Ω
	I_{OL}	Low level output current $V_{OL} = 0.27$ V	8 mA	-	-
	I_{OH}	High level output current $V_{OH} = 1.53$ V	8 mA	-	-
DVDIO=2.8V I/O (V)	V_{IL}	Active low-level input	-0.3V	-	0.7V
	V_{IH}	Active high-level input	2.1V	-	3.1V
	V_{OL}	Low-level output range	-	-	0.35V
	V_{OH}	High-level output range	2.1V	-	-
	R_{PU}	Internal pull-up resistor	40 k Ω	85 k Ω	190 k Ω
	R_{PD}	Internal pull-down resistor	40 k Ω	85 k Ω	190 k Ω
	I_{OL}	Low level output current $V_{OL} = 0.35$ V	12 mA	-	-
DVDIO=3.3V I/O (V)	V_{IL}	Active low-level input	-0.3V	-	0.8V
	V_{IH}	Active high-level input	2.4V	-	3.6V
	V_{OL}	Low-level output range	-	-	0.4V
	V_{OH}	High-level output range	2.4V	-	-
	R_{PU}	Internal pull-up resistor	40 k Ω	75 k Ω	190 k Ω
	R_{PD}	Internal pull-down resistor	40 k Ω	75 k Ω	190 k Ω
	I_{OL}	Low level output current $V_{OL} = 0.4$ V	16 mA	-	-
DVDIO=1.8V/2.8V/3.3V DVDIO*0.75 < V_{IN} < DVDIO	I_{FLIHL}	Leakage current of the float input	-5 μ A	-	5 μ A
	I_{PUIHL}	Leakage current from the pull-up input	-30 μ A	-	5 μ A
	I_{PDIHL}	Pull down the leakage current of the input	-5 μ A	-	85 μ A
DVDIO=1.8V/2.8V/3.3V 0 < V_{IN} < DVDIO*0.25	I_{FLILL}	Leakage current of the float input	-5 μ A	-	5 μ A
	I_{PUILL}	Leakage current from the pull-up input	-85 μ A	-	5 μ A
	I_{PDILL}	Pull down the leakage current of the input	-5 μ A	-	30 μ A
Input capacitor	C_{in}		5		pF
Load capacitance	C_{load}			8	pF

Table 5: General features

Pin voltage domain	Parameter	Description	Min.	Typ.	Max.
DVDIO=1.8V I/O	V _{IL}	Low level input	-0.3 V	-	0.45 V
	V _{IH}	High level input	1.35 V	-	2.1 V
	V _{OL}	Output low range	-	-	0.27 V
	V _{OH}	Output high range	1.53 V	-	-
	R _{PU}	Internal pull-up resistor	70 k Ω	150 k Ω	380 k Ω
	R _{PD}	Internal pull-down resistor	70 k Ω	150 k Ω	380 k Ω
	I _{OL}	Low level output current V _{OL} = 0.27 V	8 mA	-	-
	I _{OH}	High level output current V _{OH} = 1.53 V	8 mA	-	-
DVDIO=2.8V I/O	V _{IL}	Active low-level input	-0.3V	-	0.7V
	V _{IH}	Active high-level input	2.1V	-	3.1V
	V _{OL}	Low-level output range	-	-	0.35V
	V _{OH}	High-level output range	2.1V	-	-
	R _{PU}	Internal pull-up resistor	40 k Ω	85 k Ω	190 k Ω
	R _{PD}	Internal pull-down resistor	40 k Ω	85 k Ω	190 k Ω
	I _{OL}	Low level output current V _{OL} = 0.35 V	12 mA	-	-
	I _{OH}	High level output current V _{OH} = 2.1 V	12 mA	-	-
DVDIO=3.3V I/O	V _{IL}	Active low-level input	-0.3V	-	0.8V
	V _{IH}	Active high-level input	2.4V	-	3.6V
	V _{OL}	Low-level output range	-	-	0.4V
	V _{OH}	High-level output range	2.4V	-	-
	R _{PU}	Internal pull-up resistor	40 k Ω	75 k Ω	190 k Ω
	R _{PD}	Internal pull-down resistor	40 k Ω	75 k Ω	190 k Ω
	I _{OL}	Low level output current V _{OL} = 0.4 V	16 mA	-	-
	I _{OH}	High level output current V _{OH} = 2.4 V	16 mA	-	-
DVDIO=1.8V/2.8V/3.3V DVDIO*0.75 < V _{IN} < DVDIO	I _{FLIHL}	Leakage current of the float input	-5 uA	-	5 uA
	I _{PUIHL}	Leakage current from the pull-up input	-30 uA	-	5 uA
	I _{PDIHL}	Pull down the leakage current of the input	-5 uA	-	85 uA
DVDIO=1.8V/2.8V/3.3V 0 < V _{IN} < DVDIO*0.25	I _{FLILL}	Leakage current of the float input	-5 uA	-	5 uA
	I _{PUILL}	Leakage current from the pull-up input	-85 uA	-	5 uA

	I_{PDILL}	Pull down the leakage current of the input	-5 uA	-	30 uA
Input capacitor	C_{in}		5		pF
Load capacitance	C_{load}			8	pF

1.7 Power consumption

Table 6: Consumption data (typical value)

Parameter	Description	GPS	GPS+GLO	GPS+GAL	GPS+GA L+BDS	GPS+GLO+ GAL+BDS
Acquisition	SIM65M @VCC=3.3V, VIO=2.8V	10.5mA	12 mA	12 mA	11.5 mA	12.5 mA
Tracking		9mA	12 mA	11 mA	11.5 mA	12.5 mA
Sleep mode (UART enable)		2.4mA	2.4 mA	2.4 mA	2.4 mA	2.4 mA
Sleep mode (UART disable)		250uA	250 uA	250 uA	250 uA	250 uA
Hardware RTC		36 uA				
Software RTC		15 uA				
Acquisition	SIM65M-U @VCC=3.3V, VIO=3.3V	10.5 mA	11.5 mA	11.5 mA	11.5 mA	11.5 mA
Tracking		8.5 mA	11 mA	10.5 mA	10.5 mA	11.5 mA
Sleep mode (UART enable)		2.0 mA	2.0 mA	2.0 mA	2.0 mA	2.0 mA
Sleep mode (UART disable)		270 uA	270 uA	270 uA	270 uA	270 uA
Hardware RTC		36 uA				
Software RTC		15 uA				
Acquisition	SIM65M-W @VCC=1.8V, VIO=1.8V	12.5 mA	14 mA	13 mA	14 mA	15 mA
Tracking		9.0 mA	12 mA	12 mA	14 mA	15 mA
Sleep mode (UART enable)		2.4 mA	2.4 mA	2.4 mA	2.4 mA	2.4 mA
Sleep mode (UART disable)		210 uA	210 uA	210 uA	210 uA	210 uA
Hardware RTC		36 uA				
Software RTC		15 uA				

1.8 GNSS operating frequency

The SIM65M series is a single-band, multi-galaxy GNSS positioning module that can receive and track multi-galaxy GNSS signals. The GNSS operating frequencies are shown in the following table:

Table 7: GNSS Operating frequencies

Type	Frequency
GPS L1	1575.42±1.023MHz
GLONASS G1	1601.7±6.75MHz
Galileo E1	1575.42±1.023MHz
BeiDou B1C	1575.42±16.368MHz
BeiDou B1I	1561.098±2.046MHz

SIMCom
Confidential

1.9 A-GPS

A-GPS is the meaning of Assisted GPS, which is a system that can under certain conditions improve the startup performance, or time-to-first-fix (TTFF) of a GPS satellite-based positioning system. SIM65M Series module supports EPO file, EASY mode, SBAS and RTCM.

1.9.1 EPO™

The SIM65M Series supports the EPO (Extended Prediction Orbit) data service. The EPO data service is supporting 7/14/30-day orbit predictions to customers. It needs occasional download from EPO server. Supply of aiding information like ephemeris, almanac, rough last position and time and satellite status and an optional time synchronization signal will reduce time to first fix significantly.

The user should update the EPO files from the EPO server in the period of validity of EPO file through the internet. Then the EPO data should send to the SIM65M Series by the HOST side. SIM65M Series has the shorter cold TTFF and warm TTFF, when the A-GPS is used.

NOTE

For more information about EPO™, please contact SIMCom.

1.9.2 EASY™ Mode

EASY is the abbreviation of Embedded Assist System, it works as embedded software which accelerates TTFF by predicting satellite navigation messages from received ephemeris.

No additional computing interval for EASY task. EASY is efficiently scheduled and computed in free time of every second after GPS navigation solution.

Easy function is conceptually designed to automatically engage for predicting after first receiving the broadcast ephemeris. After a while (generally tens of seconds), 3-day extensions will be completely generated then all EASY functions will be maintained at a standby condition. EASY assistance is going to be engaged when the GPS requests in new TTFF condition or re-generates again with another new received ephemeris. Meanwhile, TTFF will be benefited by EASY assistance.

NOTE

EASY™ function is default open and can be closed by PAIR command.

1.9.3 SBAS and RTCM

① SBAS

SBAS is the abbreviation of Satellite Based Augmentation System. The SBAS concept is based on the transmission of differential corrections and integrity messages for navigation satellites that are within sight of a network of reference stations deployed across an entire continent. SBAS messages are broadcast via geostationary satellites able to cover vast areas.

Several countries have implemented their own satellite-based augmentation system. Europe has the European Geostationary Navigation Overlay Service (EGNOS) which covers Western Europe and beyond. The USA has its Wide Area Augmentation System (WAAS). Japan is covered by its Multi-functional Satellite Augmentation System (MSAS). India has launched its own SBAS program named GPS and GEO Augmented Navigation (GAGAN) to cover the Indian subcontinent.

② RTCM

SIM65M Series module supports soft RTCM, but only one mode can be applied at one time, and SBAS is the default feature, customers who want to apply RTCM in the design can contact SIMCom for supporting.

1.10 LOCUS

The module supports LOCUS technology, which is a technology that supports autonomous recording of log information and can automatically store satellite navigation data in the internal flash of the module to facilitate users to accurately analyze satellite navigation data. In addition, when this function is enabled, the module can reduce power consumption, and the host does not need to receive NMEA information all the time.

NOTE

The LOCUS function is turned off by default, and the switch can be controlled by the PAIR command, please refer to the "SIM65M Series_NMEA Message_User Guide" for more information.

1.11 AIC

The module supports multi-tone AIC (Multi-tone AIC, Active Interference Cancellation) function, which can effectively suppress or eliminate RF noise harmonics such as Wi-Fi, Bluetooth, and 2/3/4/5G.

NOTE

AIC is enabled by default, users can use the PAIR command to control the switch, please refer to "SIM65M Series_NMEA Message_User Guide" for more information.

1.12 Firmware update

The module is shipped with firmware pre-installed. SIMCom may release firmware versions that contain bug fixes or performance optimizations, so it is important to implement a firmware upgrade mechanism in the client's system. A firmware upgrade is the process of transferring a binary image file to a receiver and storing it in flash. For details on firmware upgrades, refer to the firmware upgrade manual.

2 Package Information

2.1 Pin out Diagram

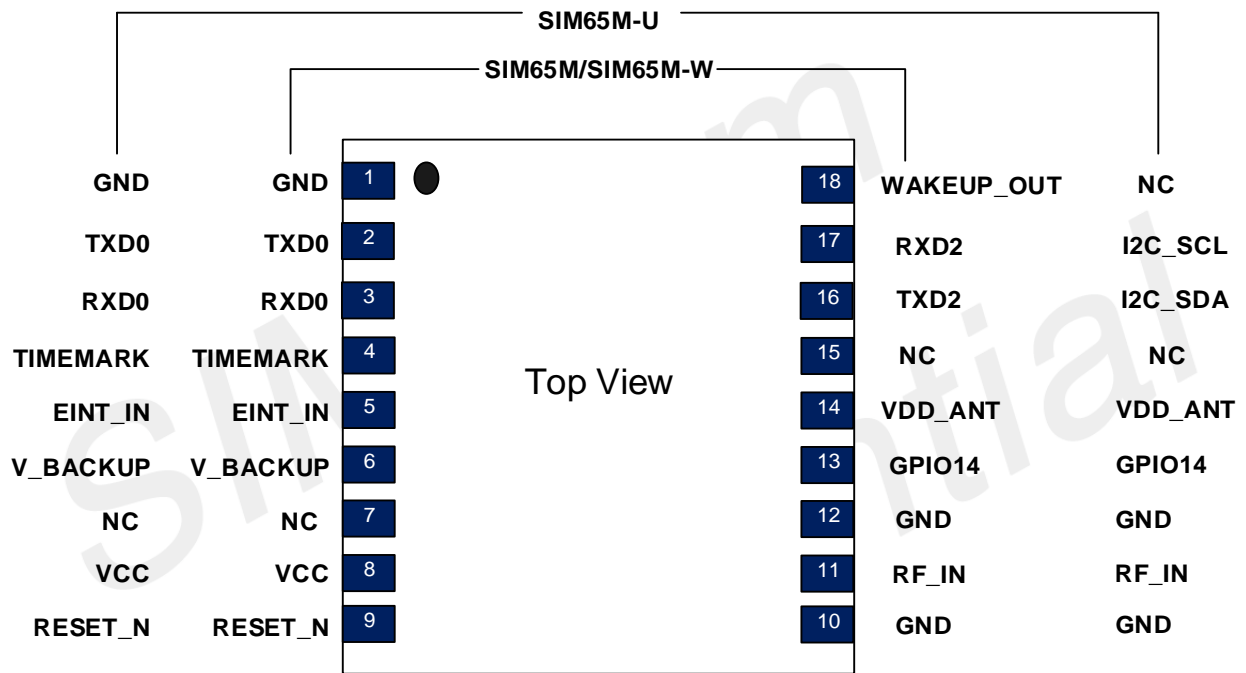

Figure 2: SIM65M Series pin diagram (Top view)

2.2 Pin Description

Table 8: I/O parameter definition

Type	Description
AI	Analog Input
AO	Analog Output
DI	Digital Input
DO	Digital Output
DIO	Digital Input/Output
PI	Power Input

PO	Power Output
OD	Open-drain

Table 9: Description of module differences

Module	Description
SIM65M	VCC power supply range: 2.8~4.3V, I/O voltage domain 2.8V, VDD_ANT output 2.8V, two UART interfaces
SIM65M-U	VCC power supply range: 3.0V~4.3V, I/O voltage domain 3.3V, VDD_ANT output 3.3V, one UART, one I2C
SIM65M-W	VCC power supply range: 1.75V~1.95V, I/O voltage domain 1.8V, VDD_ANT output 1.8V, two UART interfaces.

Table 10: Pin description

Pin name	Pin number	I/O	Description	Comment
Power supply				
VCC	8	PI	Main power input, which will be used to power the baseband and RF section internally. Input voltage range: SIM65M: 2.8~4.3V, Typ: 3.3V SIM65M-U: 3.0~4.3V, Typ: 3.3V SIM65M-W: 1.75~1.95V, Typ: 1.8V The supply current requirement can reach 100mA.	Provide clean and stable power source to this pin. Add a 4.7uF capacitor to this pin for decoupling.
VDD_ANT	14	PO	Internal power output to power the active antenna The SIM65M output 2.8V; The SIM65M-U outputs 3.3V; The SIM65M-W outputs 1.8V Delivers a maximum of 100mA	If unused, keep open. It is necessary to ensure that the active antenna used is powered within this range, otherwise it is recommended to additionally supply power to the active antenna
V_BACKUP	6	PI	The backup battery input power supply for RTC The input voltage range is 1.75V~3.60V, the typical value is 2.8V	Must be connected.
GND	1,10,12	-	Ground	GND
Communication interface				
TXD0	2	DO	NMEA serial output/ input	SIM65M 2.8V power

RXD0	3	DI		domain
TXD2/I2C_SDA	16	DO/ DIO	The default SIM65M/-W is an UART of RTCM	SIM65M-U 3.3V power domain
RXD2/I2C_SCL	17	DI	The SIM65M-U defaults to the I2C interface	If unused, keep open.
System control				
RESET_N	9	I	Input pin, which is pulled below 0.4V and held for at least 100ms before being released, can reset the module	Internal default pulls 1.8V high and supports 1.8/3.3V input
GPIOs				
WAKEUP_OUT	18	O	GNSS chip wakeup host	SIM65M 2.8V power domain SIM65M-U default NC High active
TIMEMARK	4	O	Timemark outputs timing pulse related to receiver time	After successful positioning, the default output is 1Hz pulse. SIM65M 2.8V power domain SIM65M-U 3.3V power domain If unused, keep open.
EINT_IN	5	I	Wake up module UART, low active, default pull high	SIM65M 2.8V power domain SIM65M-U 3.3V power domain If unused, keep open.
GPIO14	13	I/O	General purpose input/output	SIM65M 2.8V power domain SIM65M-U 3.3V power domain If unused, keep open..
NC	7, 15	-	-	Keep floating.
RF interface				
RF_IN	11	I	Radio antenna connection	Impedence must be controlled to 50Ω.

NOTE

1. Different modules of SIM65M series VDD_ANT have different output voltages, please choose the active antenna according to the output voltage, if the VDD_ANT output voltage does not meet the active antenna power supply range, please use the external power supply to supply power to the active antenna.
2. SIM65M-U because I2C is turned on by default, so can not open the serial port sleep function, to use the serial port sleep function to reduce sleep consumption, you need to send instructions \$PAIR861, 1,0*34 to close I2C.

2.3 Machine Dimensions

Following figure shows the Mechanical dimensions of SIM65M Series (top view, side view and bottom view).

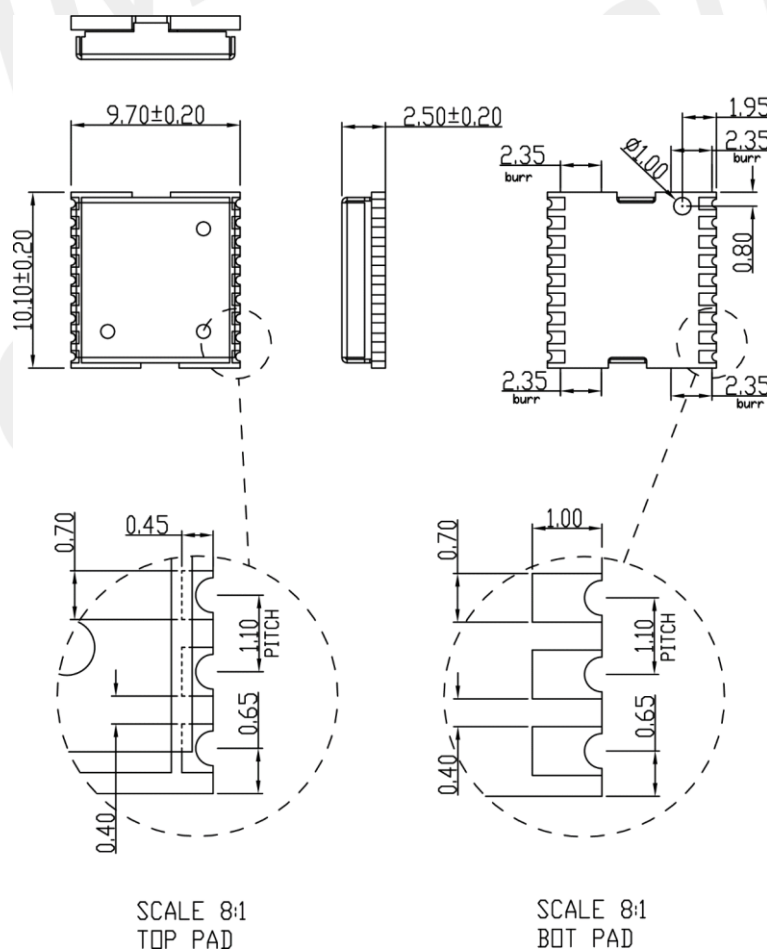

Figure 3: SIM65M Series mechanical dimensions (Unit: mm)

NOTE

Outline dimensional tolerances do not include burr areas.

SIMCom
Confidential

3 Application Interface

3.1 Power Management

3.1.1 Power Input

① VCC supply requirements

VCC is the power supply pin of the module, SIM65M-W power supply range: 1.75V~1.95V, SIM65M power supply range: 2.8V~4.3V, SIM65M-U power supply range: 3.0V~4.3V, typical value: 3.3V. The power supply should be able to provide sufficient current up to 100mA. SIM65M Series positioning modules require a stable power supply, consider the following points:

- Wide power lines or even power planes are preferred.
- VCC supply needs to add a 4.7uF and 100nF multi-layer ceramic chip (MLCC) capacitors with low ESR in high frequency band, which can be used for EMC performance .
- The ripple of the VCC supply cannot be higher than 15mV.
- VCC supply needs a ESD and surge protection.

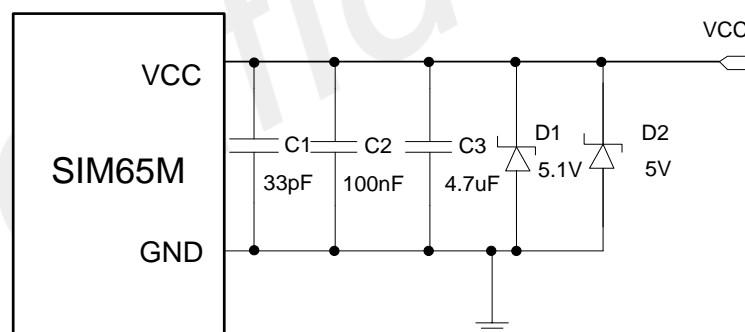

Figure 4: Power supply reference circuit

NOTE

D2 is used for ESD protection and D1 is used for surge protection.

Table 11: Recommended D1 and D2 list

No.	Manufacturer	Part number	VRWM	Package	Ref. Designator
1	JCET	ESDBW5V0A1	5V	DFN1006-2L	D2
2	WAYON	WS05DPF-B	5V	DFN1006-2L	
3	LRC	LEDZ5.1BT1G	5.1V	SOD-523	D1
4	Prisemi	PZ5D4V2H	5.1V	SOD-523	

② Backup supply

The V_BACKUP pin is backup power, and the power supply range is 2.5V~3.6V. By using valid time and GNSS track data at start-up, the module enables hot (warm) start-up. When the module is turned on, the V_BACKUP should be connected to the power supply and maintain the power supply all the time; If RTC entry is required, power is maintained V_BACKUP VCC is maintained after sending a command to enter RTC mode¹.

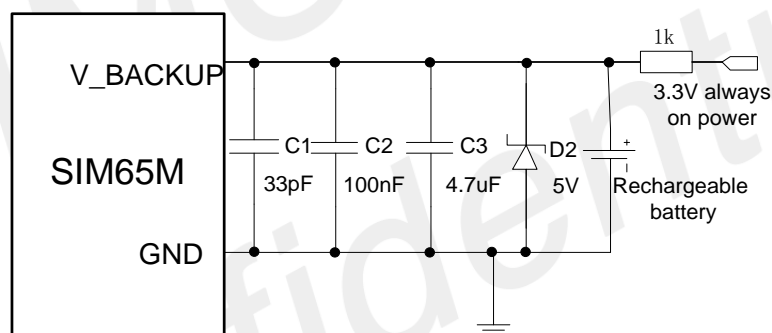

Figure 5: V_BACKUP input reference circuit

NOTE

1. The V_BACKUP voltage must not be lower than the minimum recommended operating voltage, otherwise the module may operate abnormally.
2. If a battery is connected, it is recommended to use a rechargeable battery, and please select the current limiting resistor according to the charging current requirements of the rechargeable battery

3.1.2 Power on

When power is first applied, SIM65M Series goes into operation mode. VCC should power up quickly within 50ms, and to ensure proper power-up sequencing, backup power should be started no later than

VCC, so V_BACKUP must be powered up before or at the same time as VCC. The module power-up and disconnection timing diagram is shown in Figure 6.

3.1.3 Power off

When the power supply of the module VCC is disconnected, the voltage should be guaranteed to drop rapidly within 50ms. In order to ensure that the power-on sequence is abnormal when the module is powered on next time it is powered on and restarted, ensure that the module VCC is powered down to less than 1V and maintained for at least 5s, and then perform power-on restart.

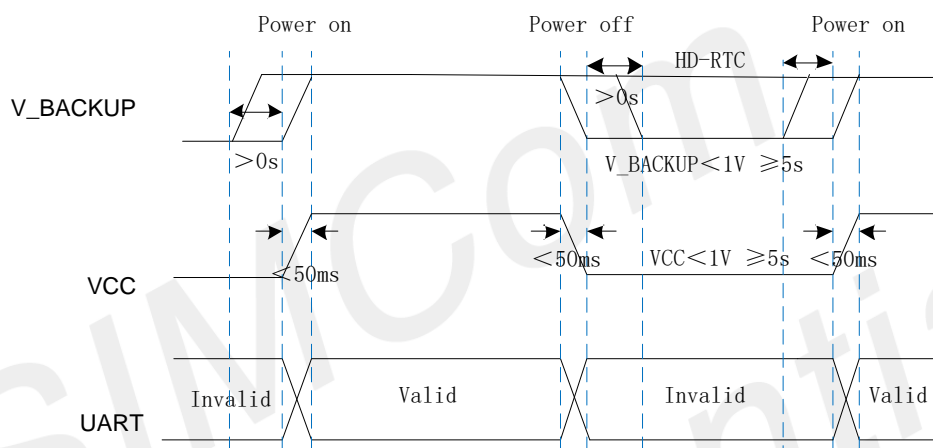

Figure 6: Timing sequence of module power-on and power-off

3.1.4 Verification of SIM65M Series Start

System activity indication depends upon the chosen serial interface:

When it is activated, SIM65M Series will output messages at the selected UART speed, and message types. The default baud rate is 115200bps.

3.1.5 Power Saving Modes

SIM65M Series supports power saving modes for reducing average power consumption like sleep mode, RTC mode.

- Sleep mode: In this mode, UART can send instructions normally. The host can wake up the module by sending a wake-up command.
- RTC mode: The host side sends instructions through the communication interface and enters the software RTC mode.

NOTE

The modes mentioned above are operated by PAIR commands, users can refer to “SIM65M Series_NMEA Message_User Guide” for more information.

3.2 Operating Mode

Table 12: Power supply and clock state according to operation mode

Mode	VCC	V_BACKUP	Internal LDO	Main clock	RTC clock
Full on	on	on	on	on	on
Sleep mode	on	on	on	off	on
RTC mode	off	on	off	off	on

3.2.1 Full on Mode

The module will enter full on mode after first power up with factory configuration settings. Power consumption will vary depending on the amount of satellite acquisitions and number of satellites in track. This mode is also referenced as full on, full power or navigation mode.

First positioning (different CN value, different positioning time), can download complete ephemeris data 15 minutes after positioning.

Navigation is available and any configuration settings are valid as long as the VCC power supply is active. When the power supply is off, settings are reset to factory configuration and receiver performs a cold start on next power up.

3.2.2 Sleep Mode

Sleep mode means a low quiescent power state, non-volatile RTC, and backup RAM block is powered on. Other internal blocks like digital baseband and RF are internally sleeping. The PMU is changed to low power mode, The power supply input VCC shall be kept active all the time, even during sleep mode. Commands can be sent through the UART interface to control the module entering/exiting sleep mode.

- Entering into sleep mode:

Send the command \$PAIR003*39\r\n, the module returns \$PAIR001,003,1*39\r\n,\$PAIR001,003,0*38\r\n, and then enter sleep mode.

- Exiting sleep mode:

Send the command \$PAIR002*38\r\n, the module returns \$PAIR001,002,1*38\r\n,\$PAIR001,002,0*39\r\n, and then exits sleep mode

NOTE

1. \$PAIR001,003,1*39\r\n indicates that the module is turning off the power, \$PAIR001,003,0*38\r\n indicates that the module is finished powering off.
2. \$PAIR001,002,1*38\r\n indicates that the module is turning on the power, \$PAIR001,002,0*39\r\n indicates that the module is finished powering on.
3. If you need to achieve lower current consumption in sleep mode, you can turn off the uart function, and the typical power consumption value is 240uA. Please refer to the “3.5 EINT_IN” section for details.

3.2.3 RTC mode

The module provides lower power consumption than sleep mode and is suitable for applications that are idle for long periods of time or where power consumption is sensitive. In RTC mode, the module stops capturing and tracking satellite signals, and only the backup domain remains active, continuing to record time.

① Software RTC Mode

- Enter software RTC mode
 1. Entering into RTC mode is controlled by UART interface, send \$PAIR650,0*25\r\n to enter RTC mode.
 2. Receive \$PAIR001,650,0*38\r\n, Receive \$PAIR650,0*25\r\n
 3. Disconnect the VCC separately and keep the V_BACKUP powered on after receiving \$PAIR650,0*25 at least 50ms.
- Exit software RTC Mode
 1. Reconnect the VCC and module will exit RTC mode automatically.

② Hardware RTC Mode

The current consumption in hardware RTC mode is twice as high as that in software RTC mode.

- Enter hardware RTC mode
 1. Disconnect the VCC separately and keep the V_BACKUP powered.
- Exit hardware RTC Mode
 1. Reconnect the VCC and module will exit RTC mode automatically.

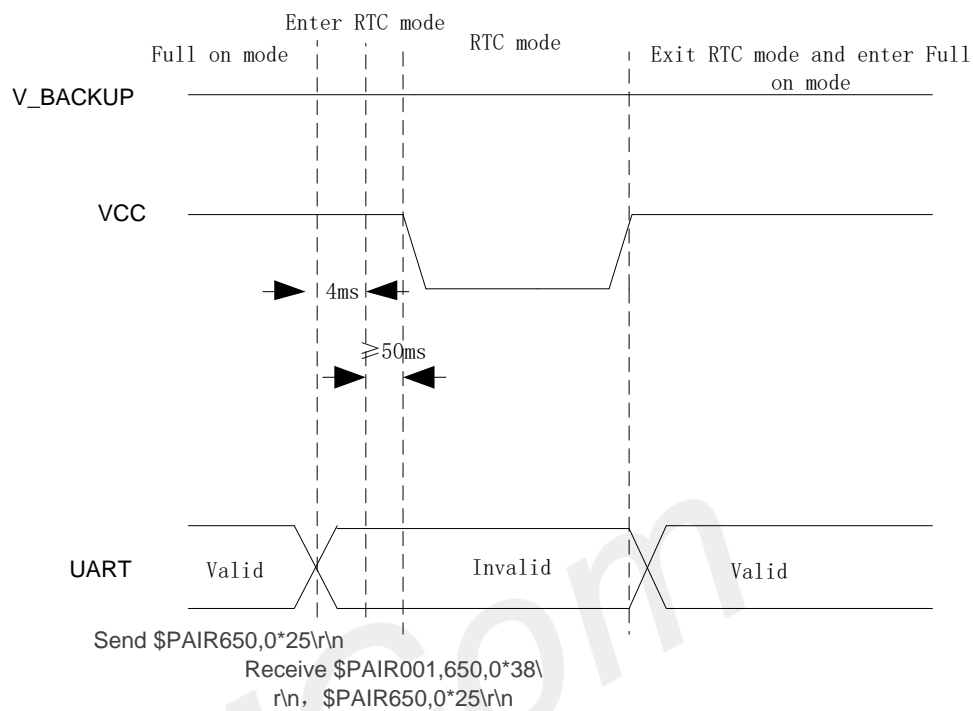

Figure 7: Enter and Exit software RTC Mode

NOTE

For command PAIR650, please refer to “SIM65M Series_NMEA Message_User Guide”.

3.3 VDD_ANT

VDD_ANT is a 1.8V/2.8V/3.3V output pin for powering an active antenna. For the detail usage of VDD_ANT, customer can refer to section 9 for details.

NOTE

1. VDD_ANT must be connected in series with a current limiting resistor of 10 ohm.
2. SIM65M-W output voltage is 1.8V typical, SIM65M output voltage is 2.8V typical, SIM65M-U output voltage is 3.3V typical.

3.4 WAKEUP_OUT Signal

SIM65M Series module WAKEUP_OUT pin can be used to wakeup host, when WAKEUP_OUT pull high 10ms that module will send a wake-up signal to the host chip before sending NMEA or other data(without command response).

1. enable external power source witch have to meeting power on sequence.
2. Pull up WAKEUP_OUT 10ms.
3. SIM65M Series module will wakeup host.

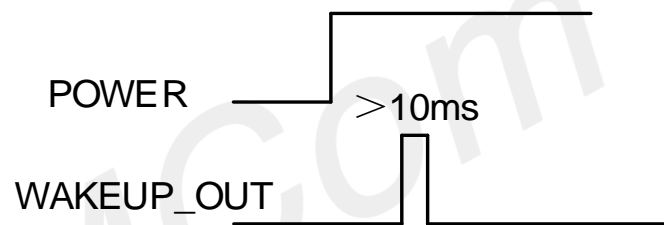

Figure 8: Wakeup host

NOTE

- 1.You can ignore this signal, if your host chip will not enter the sleep mode.
- 2.SIM65M-U module This PIN pin defaults to NC.

3.5 EINT_IN Signal

The module can be configured with UART sleep to reduce power consumption. ENIT_IN is used to wake up module from sleep.

Standard version firmware turns off this feature by default. If lower power consumption is required, you can send \$PAIR382,0*2F command to turn on the UART Sleep function. After turning on the UART sleep function, \$PAIR commands must be sent in the following timing:

1. Pull down "EINT_IN" pin at least 10ms, in the process of pulling down EINT 10ms, SIM65M Series will return \$PAIR012*39.
2. Send command within 100ms after returning \$PAIR012*39.

3.6 UART Interface

UART can provide the developers signal or message outputs. SIM65M/M-W includes two UART interfaces, SIM65M-U only one UART interface.

- UART0 interface for serial communication, and this UART support NMEA output and PAIR command input.
- UART2 is used for RTCM format data input/output for RTCM functions.

Table 13: Host port multiplexed function pins

Pin name	Pin number	I/O	Description	Comment
TXD2/SDA	16	DO	Default RTCM SIM65M-U is configured for I2C	SIM65M-W: 1.8V power domain
RXD2/SCL	17	DI		SIM65M: 2.8V power domain SIM65M-U:3.3V power domain If unused, keep open.
TXD0	2	DO	Serial data output of NMEA	SIM65M-W: 1.8V power domain
RXD0	3	DI	Serial data input for firmware update	SIM65M: 2.8V power domain SIM65M-U:3.3V power domain 2.8V power domain

NOTE

1. The default baud rate is 115200, if other baud rate required please contact SIMCom.
2. If the IO voltage of the MCU does not match the module, a level shifting circuit must be added.

The following figure shows the connection between module and client (DTE).

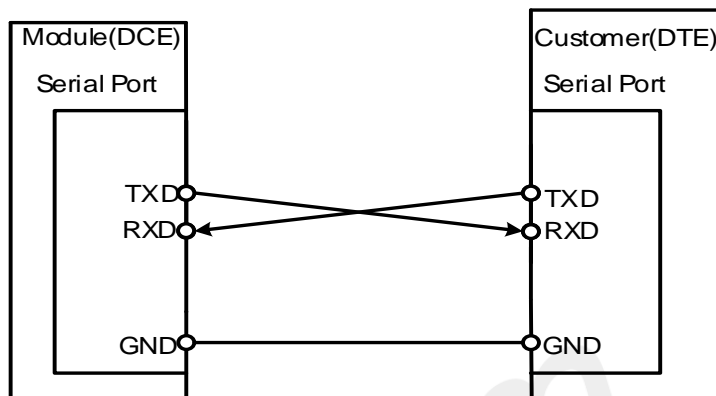

Figure 9: Connection of the serial interfaces

3.7 I2C Interface*

SIM65M-U supports one I2C interface and supports 400kHz and 1MHz modes.

The reference circuit is shown in the figure below:

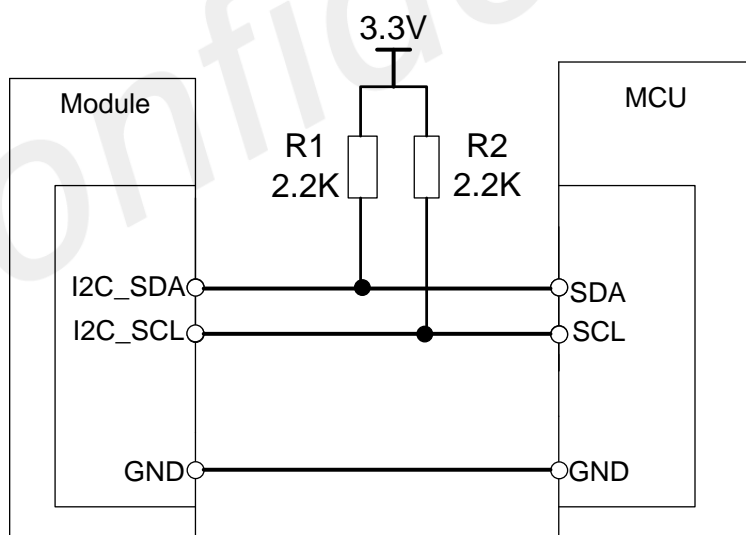

Figure 10: Connection of the i2c interfaces

NOTE

1. 2.2K resistor needs to be pulled up outside the module.
2. If the IO voltage of the MCU does not match the module, a level shifting circuit must be added.
3. When using the I2C function, the serial port sleep function cannot be enabled.

3.8 Timemark Output

The Timemark pin outputs pulse-per-second (PPS) pulse signal for precise timing purposes after the position has been fixed. The Timemark signal can be provided through designated output pin for many external applications. This pulse is not only limited to be active every second but also allowed to set the required duration, frequency, and active high/low by programming user-defined settings.

PPS GPS time reference with adjustable duty cycle and +/- 10ns accuracy, support for time service application, which is achieved by the PPS vs NMEA feature.

The following figure is the typical application of the TIMEMARK function.

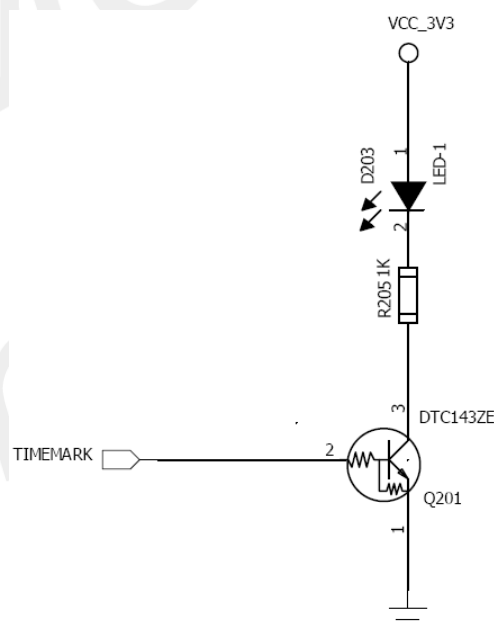

Figure 11: TIMEMARK application circuit

3.9 RESET_N

Input enable pin, pull this pin low for 100ms and then release it, which can reset the module and can be used to exit software RTC mode. This pin has been pulled up 10k resistors to 1.8V inside the module, eliminating the need to add pull-up resistors outside the module. The module has diodes inside to be compatible with 1.8V/3.3V voltage inputs. The recommended circuit is as follows:

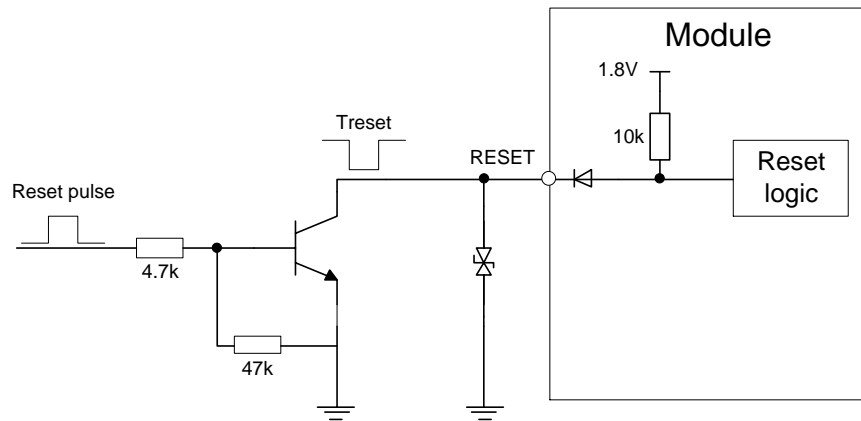

Figure 12: RESET recommended circuit

SIMCom
Confidential

4 Antenna

The antenna is the most critical item for successful GPS/GLONASS/BEIDOU/Galileo reception in a weak signal environment. Proper choice and placement of the antenna will ensure that satellites at all elevations can be seen, and therefore, accurate fix measurements are obtained.

It is recommended to use an active GPS/GLONASS/BEIDOU/Galileo antenna. In a typical application, SIM65M Series with an active antenna can get a tracking sensitivity about 3dB better than SIM65M Series with a passive antenna.

4.1 Antenna Interface

The SIM65M Series receives L1 band signals from GPS/GLONASS/BEIDOU/Galileo satellites, The RF signal is connected to the RF_IN pin. And the trace from RF_IN to antenna should be controlled to 50Ω impedance.

To suit the physical design of individual applications the RF interface pad can lead to two alternatives:

Recommended approach: solderable RF coaxial cable assembly antenna connector, such as HRS' U.FL-R-SMT (10) connector or I-PEX's 20279-001E-01 RF connector. SMA connector.

4.2 Antenna Choice Consideration

To obtain excellent GNSS reception performance, a good antenna will always be required. Proper choice and placement of the antenna will ensure that satellites at all elevations can be seen, and therefore, accurate fix measurements are obtained.

The total noise figure should be well below 3 dB.

If a patch antenna is the preferred antenna, choose a patch of at least 15x15x4 mm for standalone. GPS/QZSS, or choose a patch of at least 25x25x4 mm for GPS + GLONASS. For smaller antennas, an LNA with a noise figure <2 dB is recommended.

- Make sure the antenna is not located close to noisy parts of the circuitry (e.g. micro-controller or High Power or display).
- To optimize performance in environments with out-of-band jamming sources, use an additional SAW filter.
- The micro strip must be 50 Ω and be routed in a section of the PCB where minimal interference from

noise sources can be expected.

- In case of a multi-layer PCB, use the thickness of the dielectric between the signal and the first GND layer (typically the 2nd layer) for the micro strip calculation.
- If the distance between the micro strip and the adjacent GND area (on the same layer) does not exceed 5 times the track width of the micro strip.
- Use an external LNA if your design does not include an active antenna when optimal performance is important.

The suggested active antenna should be chosen as following:

Table 14: Antenna Specifications

Parameter	Specification	Passive and active antenna
Active Antenna Recommendations	Frequency range L1	1560~1609MHz
	Polarization	RHCP
	Gain	>20dB (max 50 dB)
	Noise Figure	<1.5 dB

4.2.1 Passive Antenna

Passive antenna contains only the radiating element, e.g. the ceramic patch, the helix structure, and chip antennas. Sometimes it also contains a passive matching network to match the electrical connection to 50 Ohms impedance.

The most common antenna type for GPS/GLONASS/BEIDOU/Galileo application is the patch antenna. Patch antennas are flat, generally have a ceramic and metal body and are mounted on a metal base plate.

Figure 13 shows a minimal setup for a GPS/GLONASS/BEIDOU receiver with SIM65M Series module.

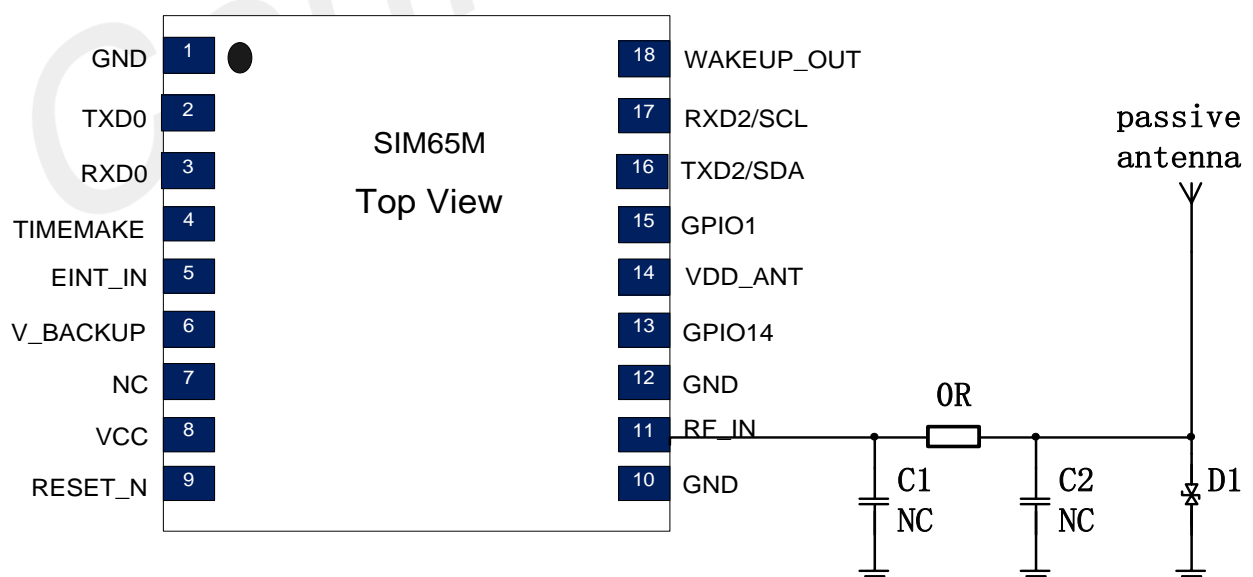

Figure 13: SIM65M Series passive antenna design

NOTE

TVS requires ultra-low junction capacitance, less than 0.2 pF is recommended.

Table 15: TVS recommended list

No	Vendor	Device	Clamping Voltage	Junction Capacitance	Package
1	Prisemi	PESDEC2XD5VBF	15V	0.15pF	DFN0603-2L
2	WAYON	WE05DGCF-B	20V	0.18pF	DFN0603-2L
3	WAYON	WE05DGCMS-BH	20V	0.15pF	DFN0603-2L
4	INPAQ	TVC5VB1SD-DFN0603-2L	4.7V	0.18pF	DFN0603-2L

For better performance with passive antenna designs user can use an external LNA to increase the sensitivity up 3~4 dB. Please see Figure 14.

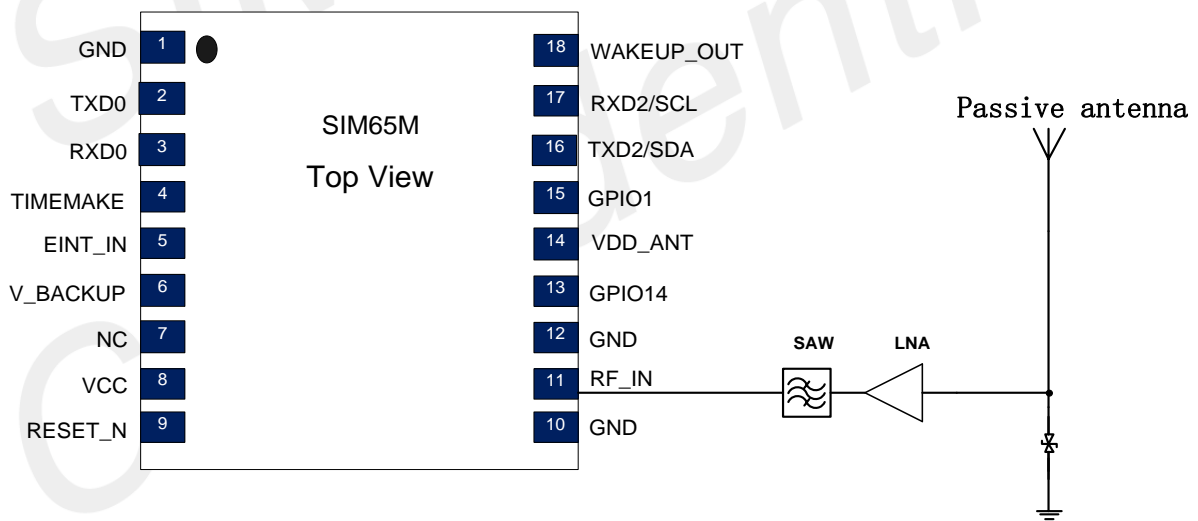

Figure 14: SIM65M Series passive antenna design (with external LNA and SAW)

For best performance, user can add an external saw based on Figure 11 design to avoid interference, please see Figure 15.

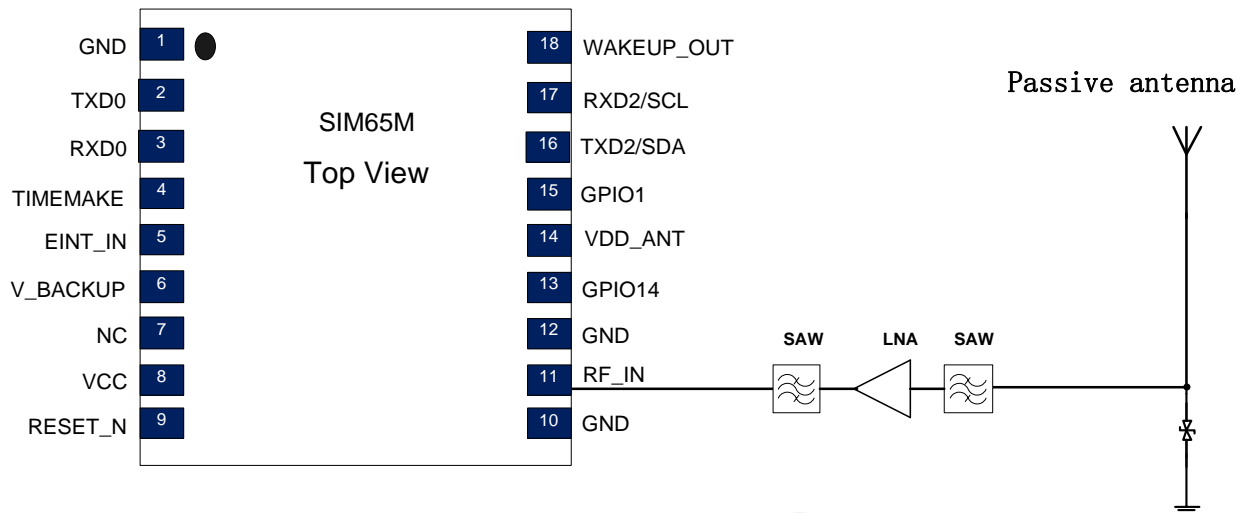

Figure 15: SIM65M Series passive antenna design

4.2.2 Active Antenna

Active antenna has an integrated Low-Noise Amplifier (LNA). Active antenna needs a power supply that will contribute to GNSS system power consumption.

Usually, the supply voltage is fed to the antenna through the coaxial RF cable shown as Figure 16. For the output voltage of pin 14, refer to the specific module model used. If the output voltage of pin 14 meets the supply voltage of the active antenna, PIN 14 VDD_ANT can be connected to RF_IN as figure 16 shows. If the requirements are not met, other power should be connected to RF_IN.

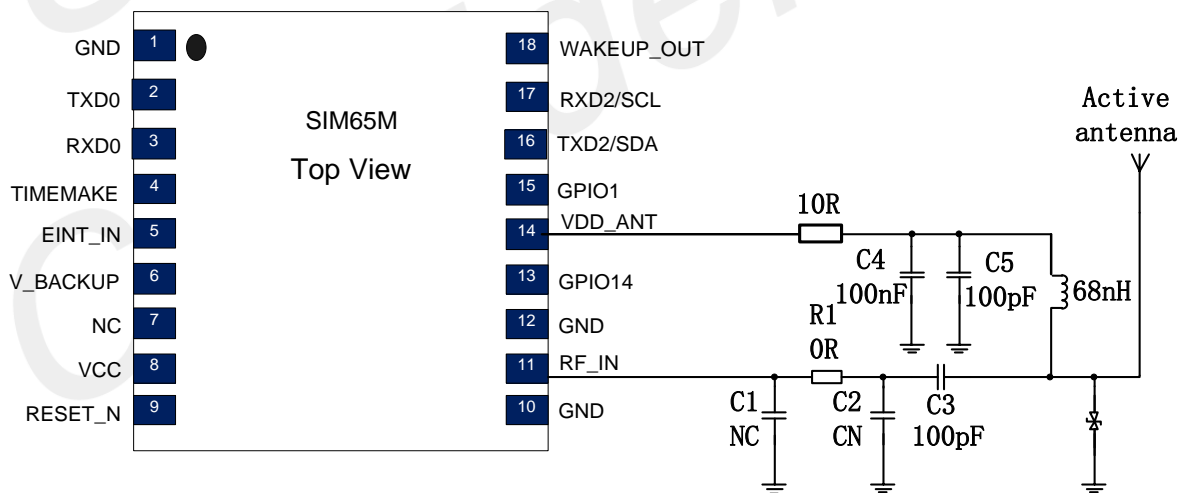

Figure 16: SIM65M Series active antenna design

If the customer's design is for automotive applications, then an active antenna can be used and located on top of the car in order to guarantee the best signal quality.

GNSS antenna choice should base on the designing product and other conditions. For detailed Antenna designing consideration, please refer to related antenna vendor's design recommendation. The antenna vendor will offer further technical support and tune their antenna characteristic to achieve successful GNSS reception performance depending on the customer's design.

5 Anti-Jamming applications

GNSS receivers typically receive signals below -130dBm and are susceptible to noise sources in the environment. The 3GPP protocol specifies that the maximum transmission power of LTE and NR PC3 is about 23dBm, and the maximum transmission power of NR PC2 is about 26dBm, when the GNSS receiver and wireless communication module coexist, the system needs to be optimized to avoid GNSS signal interference.

In the system where GNSS receivers and wireless communication modules coexist, both in-band and out-of-band jamming signals can occur, and this section will introduce the sources and effects of jamming signals, and propose anti-jamming design schemes.

5.1 In-band jamming

When the frequency of an interfering signal is within the GNSS operating band, it is called in-band jamming. In-band jamming is often generated by adjacent RF transceivers, such as in vehicle tracking and connected car solutions, where cellular communication modules used in combination with GNSS receivers are prone to jamming signals.

Because RF jamming reduces the quality of the GNSS signal and prolongs the search time, it will take longer for the GNSS receiver to achieve the first position. Because the power consumption for the first fix is significantly greater than the power consumption required for tracking after the first position, RF jamming can lead to increased power consumption, ultimately reducing battery life. Therefore, reducing RF jamming is especially important in power-constrained applications, such as battery-powered GNSS location trackers.

In some cases, RF jamming can cause GNSS signal loss, and while newer GNSS receivers can track multiple satellites in multiple GNSS constellations simultaneously, the loss of some useful signals can still lead to reduced positioning accuracy, or in the worst case, complete loss of positioning.

In the case of GPS L1, the band has a center frequency of 1575.42 MHz and a bandwidth of 2.046 MHz. When the 4G/5G communication module in the system is operating, it may generate jamming signals with frequencies between 1574.4MHz ~ 1576.4MHz, and the jamming signal power will be higher than the actual received GPS signal.

Common types of RF jamming are high-order harmonics and intermodulation distortion, which refers to the combination of frequencies of several signals of different frequencies that are the same or similar to the frequency of the useful signal when they pass through a nonlinear circuit, thereby causing jamming to the GNSS receiver. The second harmonic of LTE Band 14 and the in-band jamming caused by the intermodulation distortion of the two different signals are listed in the table below.

Table 16: Absolute maximum ratings

Signal S1	Signal S2	IM	Intermodulation distortion products
LTE Band 14	N/A	2 × S1 (788 MHz)	2nd harmonic = 1576 MHz
Wi-Fi 2.4 GHz	LTE Band 5	S1 (2412 MHz) - S2 (836.5 MHz)	2nd order intermodulation = 1575.5MHz
LTE Band 3	LTE Band 2	2 × S1 (1727.5 MHz) - S2 (1880 MHz)	3rd order intermodulation = 1575 MHz
Wi-Fi 5 GHz	LTE Band 2	S1 (5295 MHz) - 2 × S2 (1860 MHz)	3rd order intermodulation = 1575 MHz

5.2 Out-of-band jamming

When the frequency of an interfering signal is outside the GNSS operating band, it is called out-of-band jamming. Out-of-band jamming can leak into the GNSS receiver's spectrum. When the out-of-band signal is strong, it is important to suppress the out-of-band signal in advance, because the GNSS module's low-noise amplifier (LNA) has a maximum output limit, and the strong signal flow transmitted by other communication systems may cause the LNA to saturate, reduce the gain, pre-filter the out-of-band signal, and the useful signal can obtain better gain. Therefore, band-pass filters can be used to reject signals outside the frequency band used.

In practical applications, common strong jamming signals usually come from wireless communication modules, such as LTE, NR, Wi-Fi signals, etc.

5.3 Anti-Jamming design

In order to reduce the influence of interference signals on GNSS reception performance, the following anti-interference design scheme is proposed:

- The receiving antenna of the GNSS module should be as far away as possible from the transmitting antenna of the cellular communication module, and it is recommended that the isolation between the antennas be greater than 15dB.
- When the GNSS module and the wireless communication module coexist, the interference source usually has RF power amplifier, single-chip microcomputer, crystal, etc., in the PCB ornament and layout, the interference source should be far away from the GNSS module, the use of shielding frame and shielding cover to ensure sufficient grounding, can effectively prevent strong signal interference.
- Using a narrowband antenna, tuning the antenna to only receive the working band of GNSS can filter out a part of the out-of-band noise and interference signals;
- Refer to Figure 14, the additional use of surface acoustic wave filters (SAWs) can effectively suppress out-of-band interference and improve the signal-to-noise ratio.

6 Electrical Characteristics

6.1 Absolute Maximum Ratings

The absolute maximum ratings stated in Table 17 are stress ratings under non-operating conditions. Stresses beyond any of these limits will cause permanent damage to SIM65M Series.

Table 17: Absolute maximum ratings

Parameter		Min	Max	Unit
VCC	@SIM65M-W	-	1.98	V
	@SIM65M	-	4.5	V
	@SIM65M-U	-	4.5	
V_BACKUP		-	3.6	V
I/O pin voltage	@V _{IO} =1.8V	-	1.98	V
	@V _{IO} =2.8V	-	3.08	V
	@V _{IO} =3.3V	-	3.63	V
Storage temperature		-45	+95	°C
Operating temperature		-40	+85	°C

6.2 Recommended Operating Conditions

Table 18: SIM65M Series operating conditions

Parameter	Symbol	Min	Typ	Max	Unit
Operating temperature range		-40	+25	+85	°C
Main supply voltage	VCC @SIM65M-W	1.75	1.8	1.95	V
	VCC @SIM65M	2.8	3.3	4.3	V
	VCC @SIM65M-U	3.0	3.3	4.3	V
VDD_ANT Active antenna supply voltage output	VDD_ANT@SIM65M-W	1.75	1.8	1.95	V
	VDD_ANT@SIM65M	2.7	2.8	2.9	V
	VDD_ANT@SIM65M-U	3.0	3.3	3.4	V
	I _{max}			100	mA
Backup battery voltage	V_BACKUP	2.5	2.8	3.6	V

6.3 Electro-Static Discharge

The GPS engine is not protected against Electrostatic Discharge (ESD) in general. Therefore, it is subject to ESD handling precautions that typically apply to ESD sensitive components. Proper ESD handling and packaging procedures must be applied throughout the processing, handling and operation of any application using a SIM65M Series module.

Table 19: The ESD characteristics (Temperature: 25°C, Humidity: 45 %)

Pin	Contact discharge	Air discharge
VCC	± 4 kV	± 8 kV
GND	± 4 kV	± 8 kV
VDD_ANT	± 4 kV	± 8 kV
RF_IN	± 4 kV	± 8 kV

NOTE

Test conditions:

1. The external of the module has surge protection diodes and ESD protection diodes.
2. The data in Table 19 were tested using SIMCom EVB.

7 Manufacturing

7.1 Top and bottom View of SIM65M Series



Figure 17: Top and bottom view of SIM65M

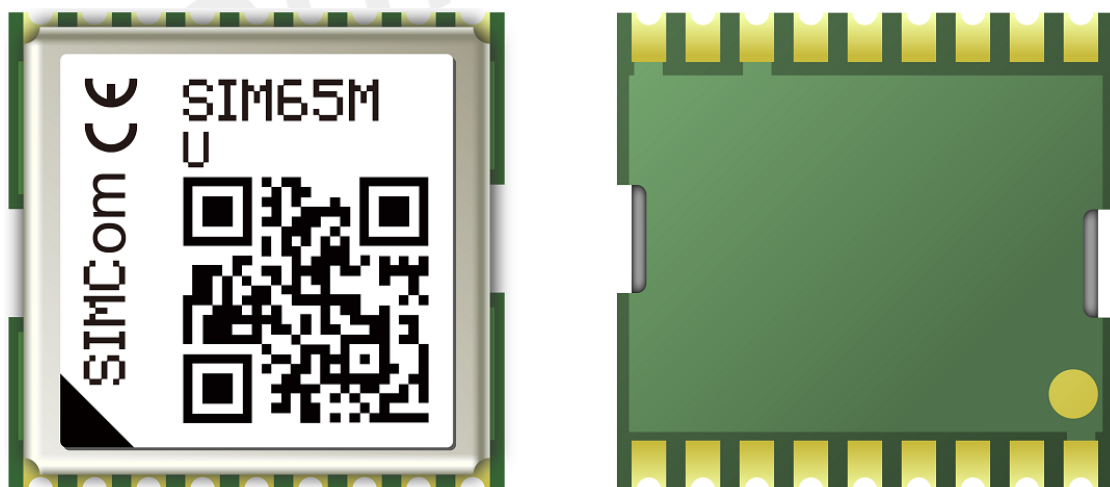

Figure 18: Top and bottom view of SIM65M-U

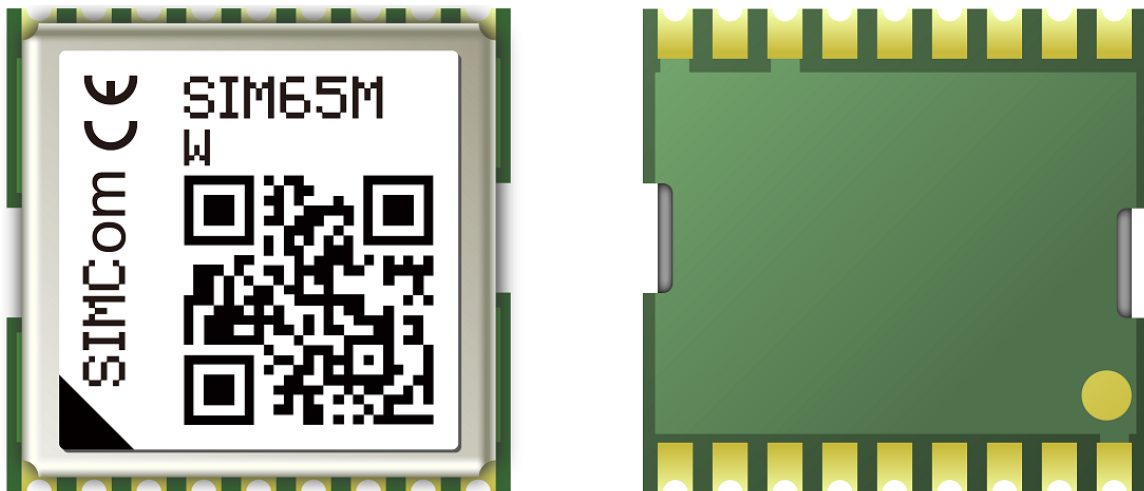

Figure 19: Top and bottom view of SIM65M-W

7.2 Label Description Information

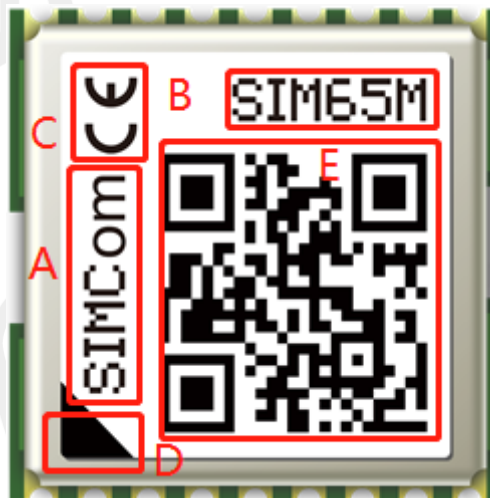

Figure 20: Label description of module information

Table 20: Label description of module information

No.	Description
A	Logo
B	Project name
C	Authentication
D	1 pin identification
E	QR code, Contains P/N, SN and SW information

NOTE

The above is the design effect diagram of the module for reference. The actual appearance is subject to the actual product.

7.3 Recommended PCB Footprint

The following figure shows the PCB footprint of the modules:

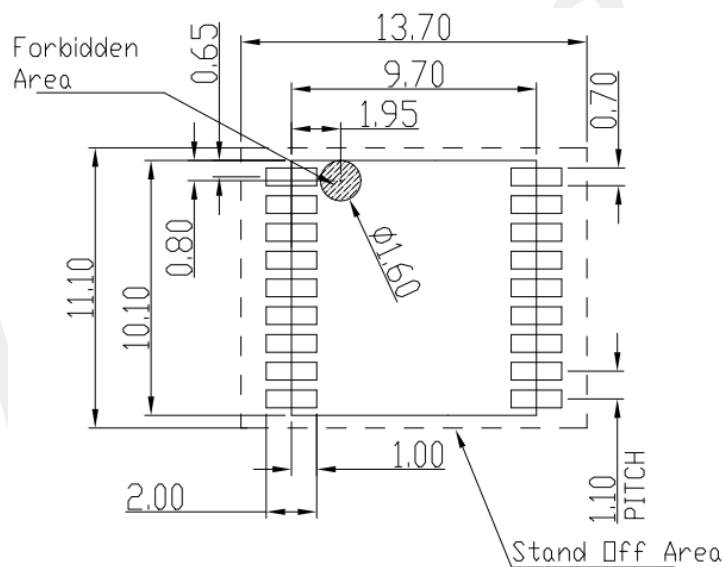

Figure 21: Recommended PCB footprint (top view) (Unit: mm)

7.4 Recommended SMT Stencil

The following figure shows the SMT stencil of SIM65M Series:

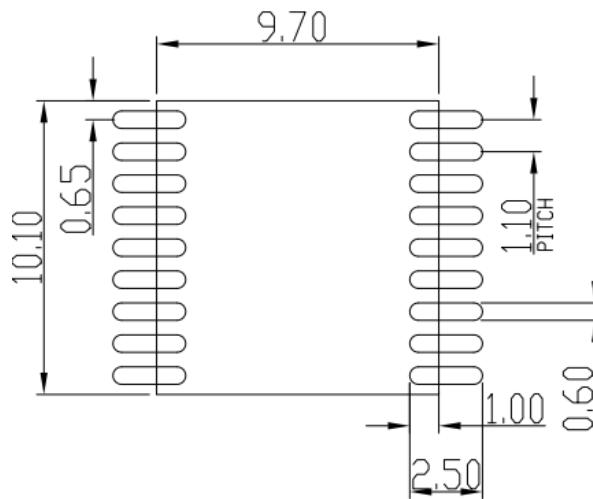

Figure 22: Recommended SMT stencil(top view)

7.5 Recommended reflow furnace temperature curve

The following figure is the Ramp-Soak-Spike Reflow Profile of SIM65M Series:

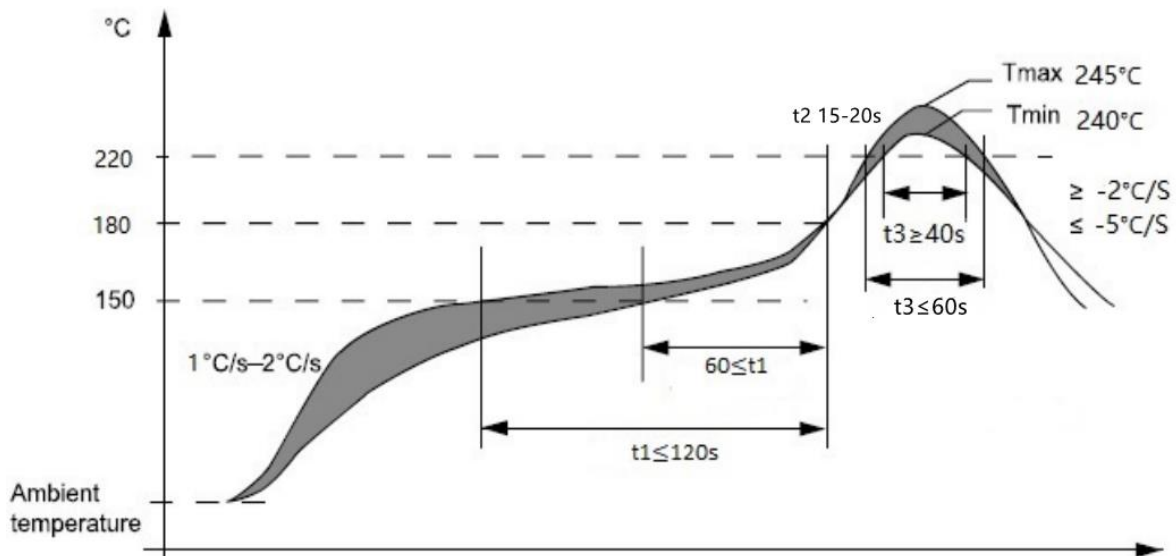

Figure 23: Recommended reflow furnace temperature curve (lead-free)

Table 21: The main board reflux temperature curve requirements (lead-free)

Zone	Time	Parameter
Preheat Zone (Room temperature~150°C)	NA	Heating rate: 1~2°C/s
T1 (150~180°C)	60~120s	/
T2 (180~220°C)	15~20s	/
T3 (≥220°C)	40~60s	Peak temperature: 240~245°C
Cooling Zone	NA	Cooling rate: -2~-5°C/s

NOTE

- Recommended lead-free process.
- In the table above, the temperature testing location includes the solder mask of the module MCU pins, bottom LGA pins, and external LCC pins.
- The actual welding temperature is affected by other external factors, such as the presence of furnace carriers, solder paste, size and thickness of the substrate, and component resistance. Thermal requirements and panel design, etc. Please confirm with our engineering and technical personnel in time if the recommended parameters cannot be reached. Otherwise, the module may be damaged.
- For boards with thickness less than 1.2mm, it is recommended to use board supported by furnace carrier or high Tg to prevent warping and PCB when heated. Deformation, thus affecting module welding. For modules larger than 35.0 mm *35.0 mm and 5G products, it is recommended to use the furnace carrier to pass through the furnace to reduce the cause of the bottom plate and mold. Due to the difference of Tg value of block, the phenomenon of unbalanced thermal stress appears in the process of high temperature welding reflow, resulting in the defect rate of virtual welding and little tin.
- After the module is welded, X-ray and optical inspection methods shall be used to check the welding quality. For specific standards, please refer to relevant standards of IPC-A-610H.
- For more information about shipping and manufacturing, please refer to “Module Secondary SMT Process User Guide”.
- Due to the complexity of the SMT process, in case of uncertainty or processes not mentioned in this document (such as selective wave soldering, ultrasonic welding), please contact SIMCom support team before SMT process starts.

7.6 Moisture Sensitivity Level and Storage conditions

Modules are shipped in vacuum-sealed aluminum foil bag bags, vacuum packaging according to IPC/JEDEC standard J-STD-020C specification.

- Recommended storage conditions: temperature $23^{\circ}\text{C} \pm 5^{\circ}\text{C}$, and relative humidity 35%~60%.
- Storage period: 12 months (Under recommended storage conditions and in sealed vacuum packaging).

The module meets the humidity sensitivity level 3 (MSL-3), and the storage period after unpacking is shown in table below.

The out-of-bag floor life of the module with MSL-3 is 168 hours. If the workshop temperature is $23^{\circ}\text{C} \pm 5^{\circ}\text{C}$ and the relative humidity is less than 60%, the module needs to be unpacked within 168 hours of reflux production or other high temperature operations. Otherwise, the module shall be stored in an environment with relative humidity less than 10% (for example, a moisture-proof cabinet) to keep the product dry.

Table 22: MSL levels

MSL	Out-of-bag floor life	Comment
1	Unlimited	$\leq +30^{\circ}\text{C}/85\% \text{ RH}$
2	1 year	$\leq +30^{\circ}\text{C}/60\% \text{ RH}$
2a	4 weeks	
3	168 hours	
4	72 hours	
5	48 hours	
5a	24 hours	
6	Mandatory bake before use. After bake, it must be reflowed within the time limit specified on the label.	

Before use, it is necessary to confirm whether the package is in good condition; After unpacking, check the status of humidity indicator card in vacuum bag (Figure 24). The module needs to be baked before use if any of the following conditions occur.

- Explanation Humidity indicator card: 30%, 40%, and 50% of any indicator circle has discolouring
- The module has been un-packed and the module exceeds the humidity sensitivity level corresponding to the exposed workshop time. For example, MSL=3 is 168.
- Packed, but the Shelf Life exceeds 12 months;
- Exceeds the Floor Life;
- Unable to track and determine the status of the module.

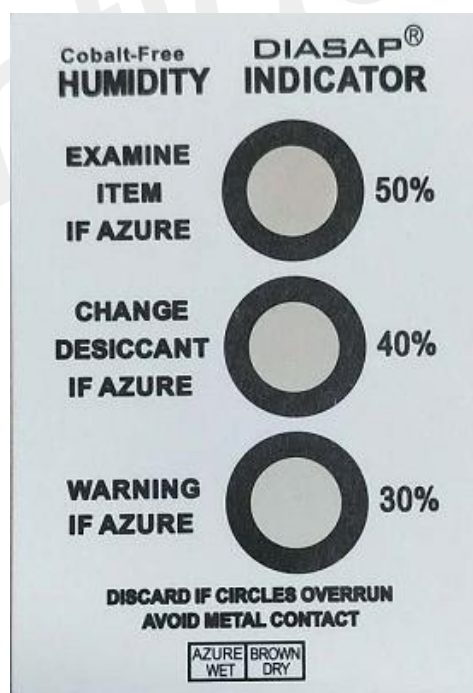

Figure 24: Humidity card

The following conditions also need to be pre-baked.

- The storage temperature and humidity do not meet the recommended storage conditions.
- Vacuum sealed bag leak, bulk materials
- Before repairing the module.
- After unpacking, the module failed to complete production or storage under the control of humidity sensitive level 3.

7.7 Baking Requirements

If baking is required, proceed according to the requirements in the table below. Preferentially choose a nitrogen-filled oven.

Table 23: Baking requirements

Baking conditions	Baking time	Comment
120°C±5°C, <5% RH	8 hours	Not applicable to original packaging pallets

NOTE

- In order to prevent and reduce the occurrence of poor welding caused by moisture, such as foaming and delamination, the module should be strictly controlled. It is not recommended to expose the module to air for a long time after unpacking the vacuum package.
- Before baking, it is necessary to remove the module from the package and place the bare module on the high temperature resistant device to avoid high temperature damage to the plastic tray or coil; The modules for secondary baking must be welded within 24 hours after baking, otherwise they need to be stored in vacuum packaging or in a drying oven.
- Please pay attention to ESD protection when unpacking and placing modules, such as wearing anti-static gloves.

8 Packaging

Module support tray and reel packaging. The module is packaged in trays by default, select REEL if reel packaging is required.

8.1 Tray packaging

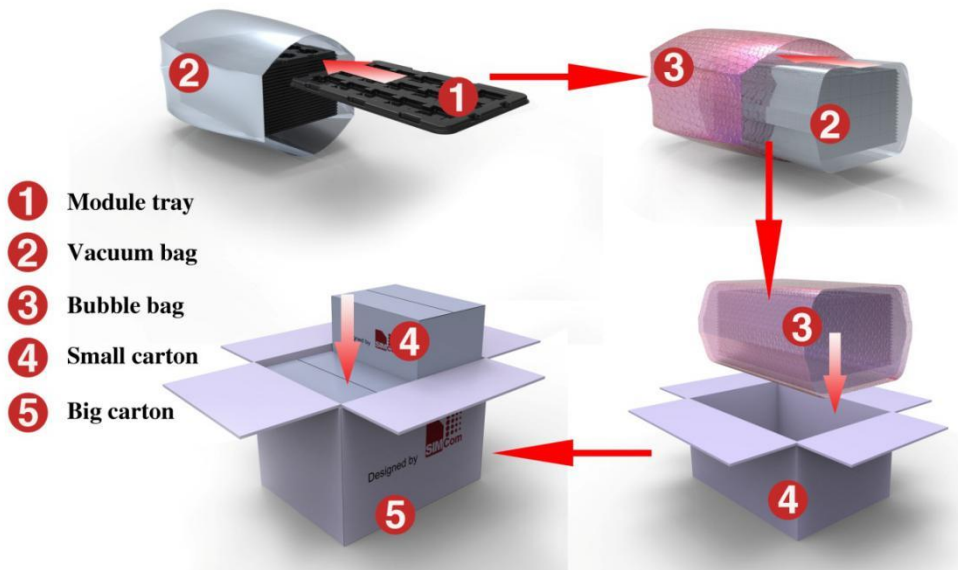

Figure 25: packaging diagram

Module tray drawing:

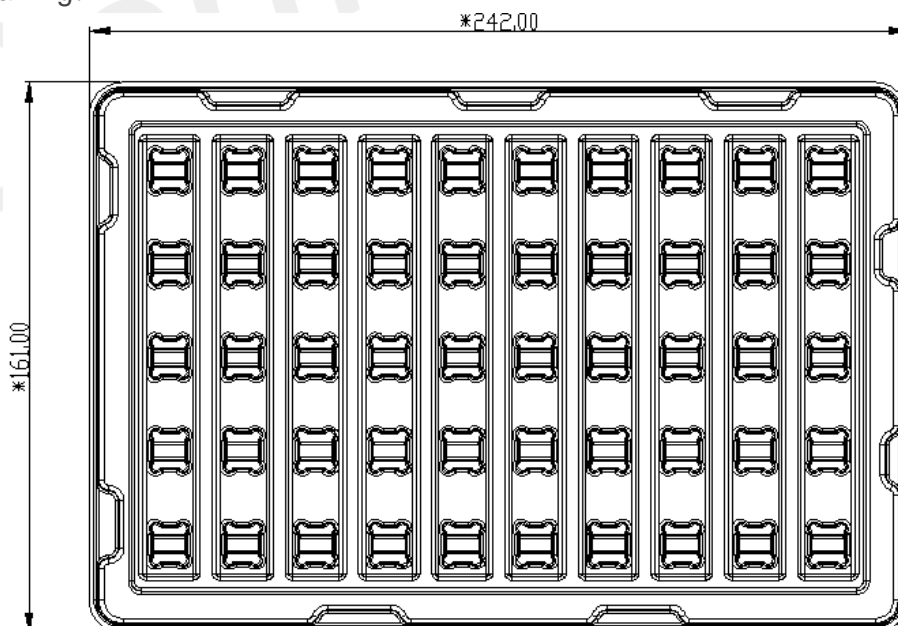

Figure 26: Tray drawing

Table 24: Tray size

Length ($\pm 3\text{mm}$)	Width ($\pm 3\text{mm}$)	Module number
242.0	161.0	50

Small carton drawing:

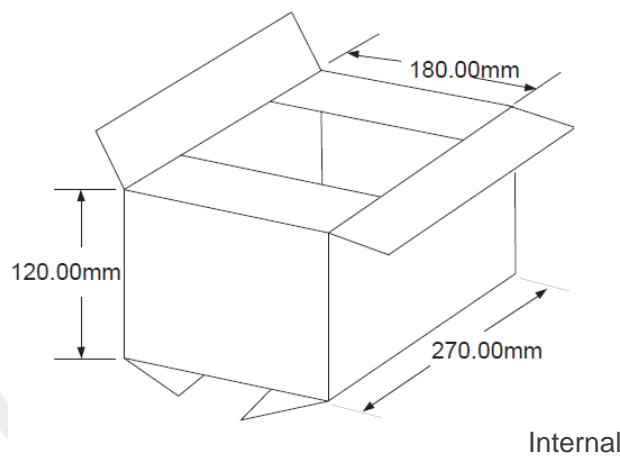

Figure 27: Small carton drawing

Table 25: Small Carton size

Length ($\pm 10\text{mm}$)	Width ($\pm 10\text{mm}$)	Height ($\pm 10\text{mm}$)	Module number
270	180	120	50*20=1000

Big carton drawing:

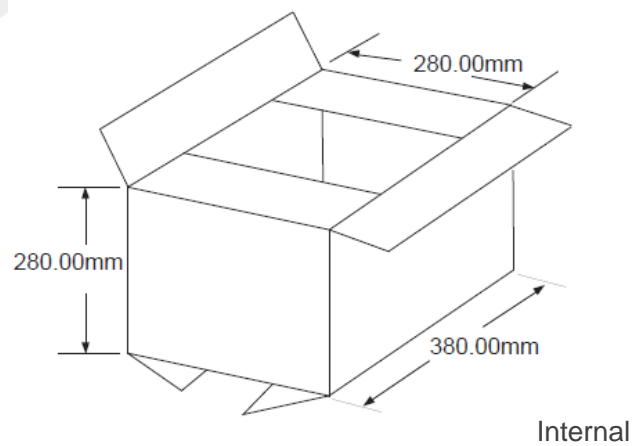

Figure 28: Big carton drawing

Table 26: Big Carton size

Length ($\pm 10\text{mm}$)	Width ($\pm 10\text{mm}$)	Height ($\pm 10\text{mm}$)	Module number
380	280	280	1000*4=4000

8.2 Reel packaging

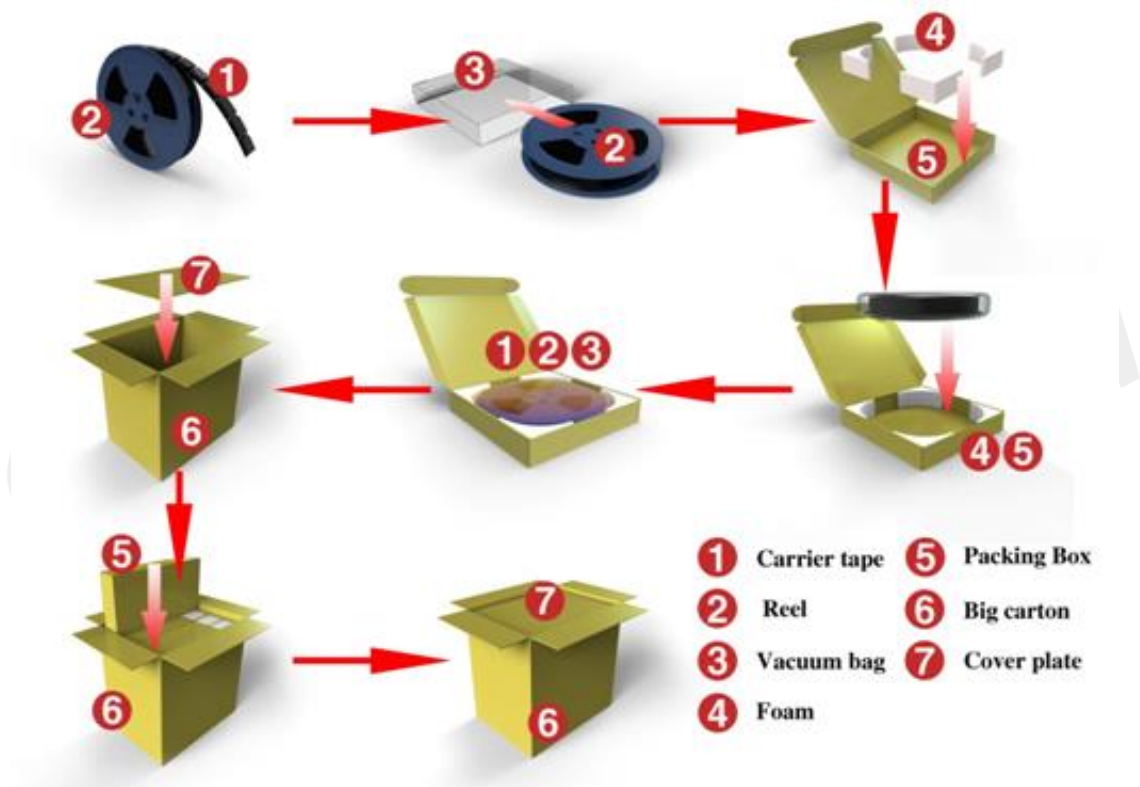

Figure 29: Packaging introduce

Carrier tape drawing:

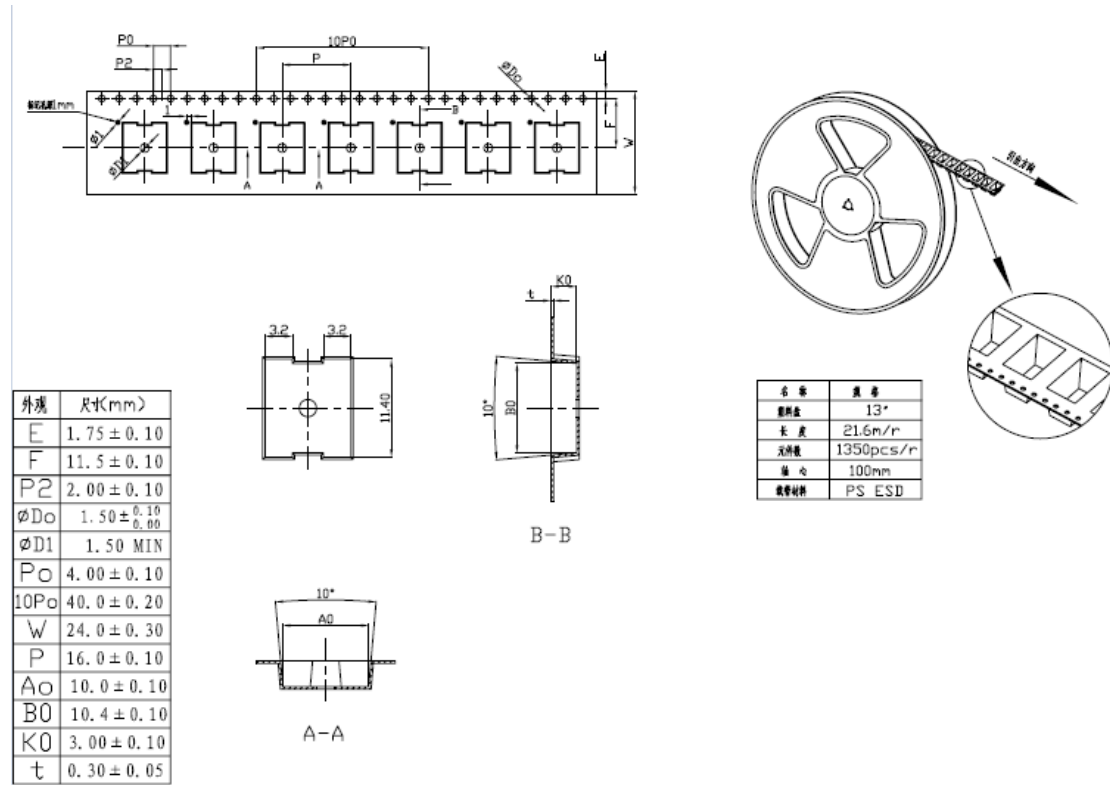

Figure 30: Carrier tape drawing introduce

Table 27: Reel size

External Diameter (mm)	Width (mm)	Inside Diameter (mm)	Module number
330.0	24.0	100.0	1000

Packing box drawing:

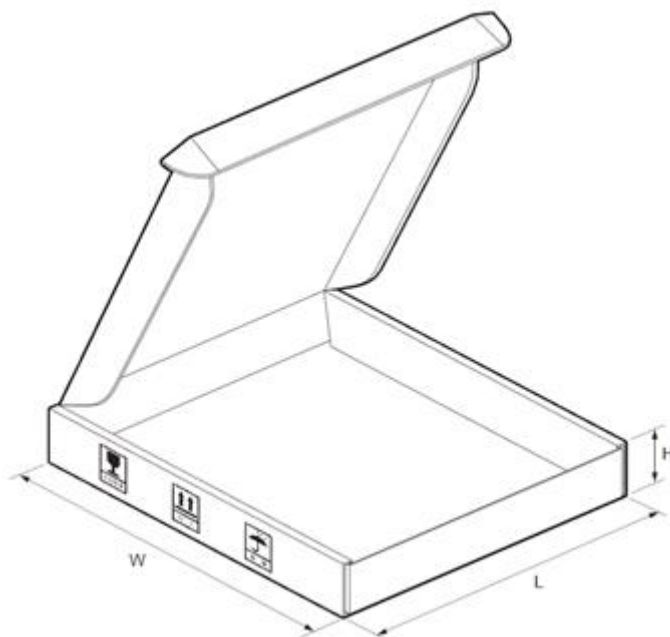

Figure 31: Packing box drawing introduce

Table 28: Packing box size

Length ($\pm 10\text{mm}$)	Width ($\pm 10\text{mm}$)	Height ($\pm 10\text{mm}$)	Module number
345	340	60	1000

Big carton drawing:

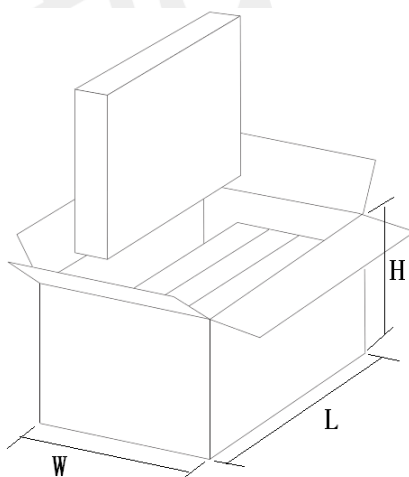

Figure 32: Big carton drawing introduce

Table 29: Big carton size

Length ($\pm 10\text{mm}$)	Width ($\pm 10\text{mm}$)	Height ($\pm 10\text{mm}$)	Module number
380	275	380	1000*4=4000

9 Reference Design

Following figure is the typical application of SIM65M Series with active antenna which supplied by VDD_ANT. If customer applies other kind of active antenna, keep PIN 14 floating and connect other voltage to the R125.

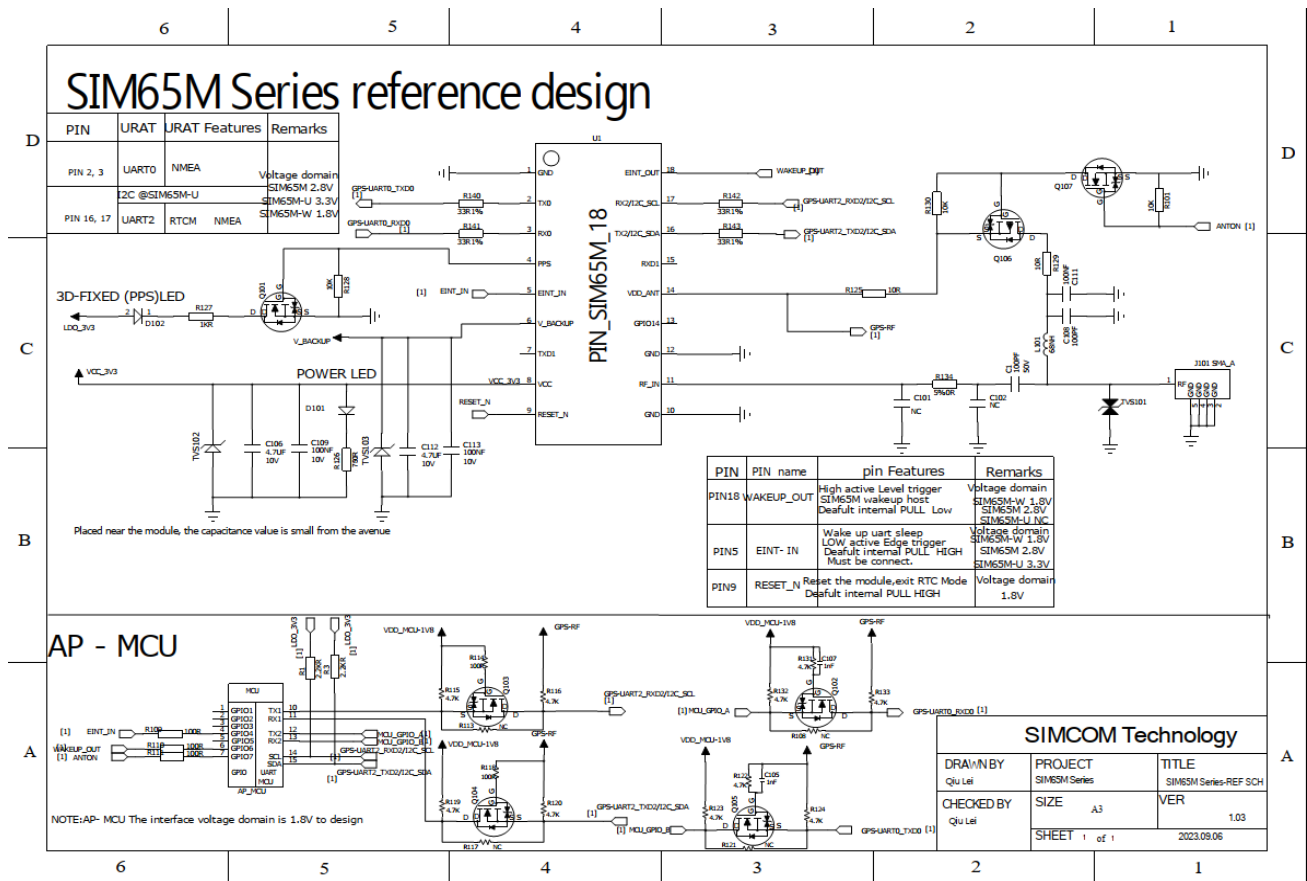

Figure 33: Refer schematic

NOTE

The IO levels of SIM65M series are different; attentions should be paid if the voltage level of the host controller not compatible.

10 Appendix

10.1 Related Documents

Table 30: Related documents

SN	Document name	Remark
[1]	SIM68D _EVB_User Guide	
[2]	SIM65M Series_NMEA Message_User Guide	
[3]	SIM65M REFERENCE DESIGN	
[4]	SIMCom GNSS Hardware Design Manual_V1.00	
[5]	Module Secondary SMT Process User Guide_V1.01	
[6]	SIMCom Standard module ESD surge protection design manual_V1.00	

10.2 Terms and Abbreviations







Table 31: Terms and abbreviations

Abbreviation	Description
A-GPS	Assisted- Global Positioning System
CMOS	Complementary Metal Oxide Semiconductor
DGPS	Difference Global Positioning System
EASY	Embedded Assist System
EGNOS	Euro Geostationary Navigation Overlay Service
EPO	Extended Prediction Orbit
ESD	Electrostatic Sensitive Devices
FSM	Finite State Machine
GAGAN	The GPS Aided Geo Augmented Navigation
GPS	Global Positioning System
GNSS	Global Navigation Satellite System
I/O	Input/Output
IC	Integrated Circuit
Inorm	Normal Current
Imax	Maximum Load Current
kbps	Kilo bits per second
LNA	Low Noise Amplifier

MSAS	Multi-Functional Satellite Augmentation
MSL	moisture sensitive level
NMEA	National Marine Electronics Association
QZSS	Quasi-Zenith Satellites System
RTCM	Radio Technical Commission for Maritime Services
SBAS	Satellite Based Augmentation Systems
WAAS	Wide Area Augmentation System

10.3 Safety Caution

Table 32: Safety caution

Marks	Requirements
	When in a hospital or other health care facility, observe the restrictions about the use of mobiles. Switch the cellular terminal or mobile off, medical equipment may be sensitive and not operate normally due to RF energy interference.
	Switch off the cellular terminal or mobile before boarding an aircraft. Make sure it is switched off. The operation of wireless appliances in an aircraft is forbidden to prevent interference with communication systems. Forgetting to think much of these instructions may impact the flight safety, or offend local legal action, or both.
	Do not operate the cellular terminal or mobile in the presence of flammable gases or fumes. Switch off the cellular terminal when you are near petrol stations, fuel depots, chemical plants or where blasting operations are in progress. Operation of any electrical equipment in potentially explosive atmospheres can constitute a safety hazard.
	Your cellular terminal or mobile receives and transmits radio frequency energy while switched on. RF interference can occur if it is used close to TV sets, radios, computers or other electric equipment.
	Road safety comes first! Do not use a hand-held cellular terminal or mobile when driving a vehicle, unless it is securely mounted in a holder for hands free operation. Before making a call with a hand-held terminal or mobile, park the vehicle.
	<p>Mobiles operate over radio frequency signals and cellular networks and cannot be guaranteed to connect in all conditions, especially with a mobile fee or an invalid (U)SIM card. While you are in this condition and need emergent help, please remember to use emergency calls. In order to make or receive calls, the cellular terminal or mobile must be switched on and in a service area with adequate cellular signal strength.</p> <p>Some networks do not allow for emergency call if certain network services or phone features are in use (e.g. lock functions, fixed dialing etc.). You may have to deactivate those features before you can make an emergency call.</p> <p>Also, some networks require that a valid (U)SIM card be properly inserted in the cellular terminal or mobile.</p>